

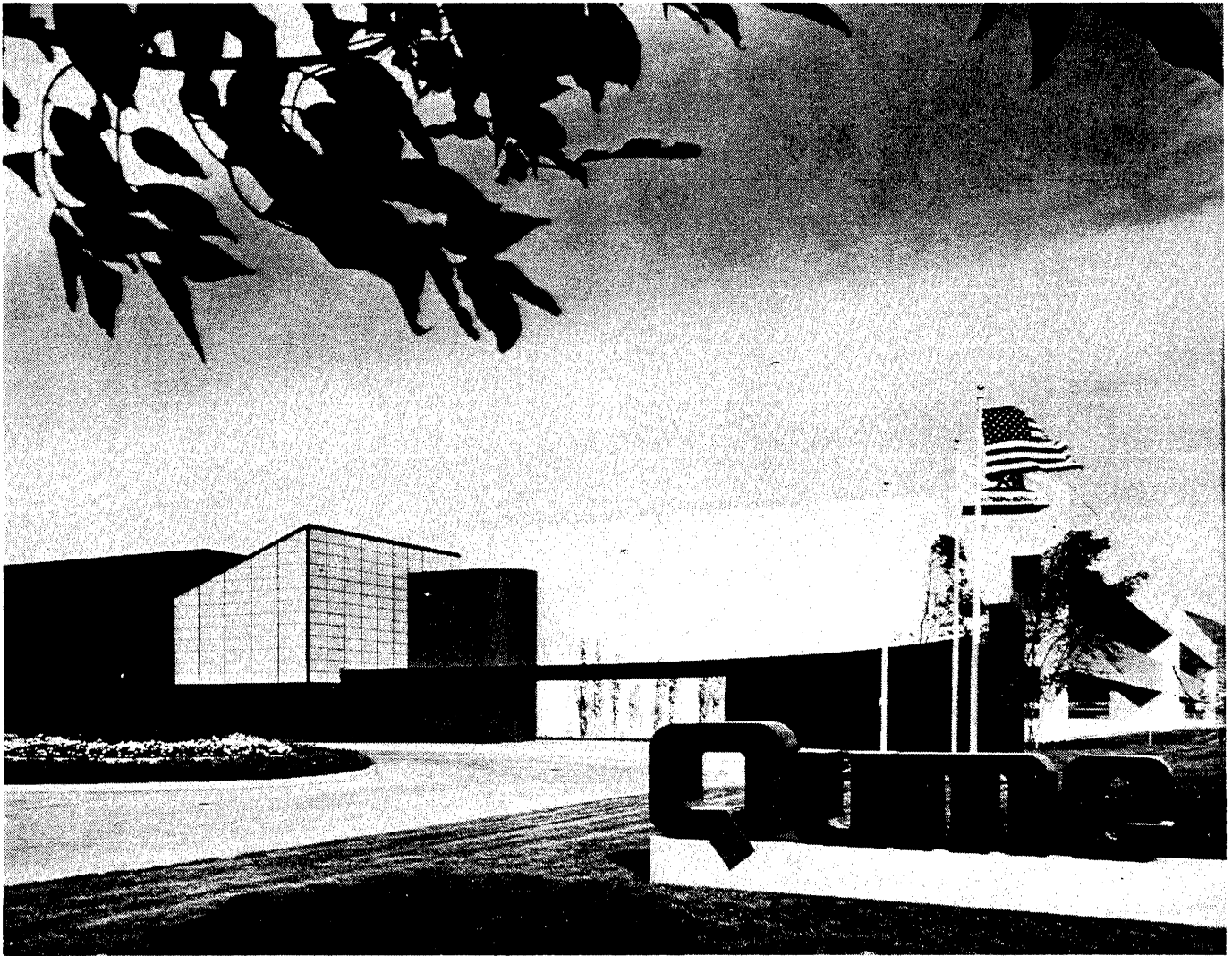

**M
a
i
n
t
e
n
a
n
c
e**

**QumeTrak 142
Maintenance**

May 1983



FOREWORD

This manual is one of a group of publications concerning the QumeTrak 142 Flexible Disk Drive. Each manual documents the entire disk drive, but from a different aspect. Some subjects may be found in more than one publication, with the text description being more or less technically detailed as required for the intended reader.

Title	Publication Number
QumeTrak 142 Product Description	36043
Memory Products Service and Spares Catalog	37052

TABLE OF CONTENTS

	PAGE
INTRODUCTION	1
SCOPE OF MANUAL.....	1
GENERAL DESCRIPTION.....	1
OPTIONS.....	1
SPECIFICATIONS SUMMARY.....	2
COMPATIBILITY.....	3
WARRANTY, SERVICE AND TRAINING.....	3
Warranty and Service.....	3
Training.....	3
FM RECORDING FORMAT.....	4
MFM RECORDING FORMAT.....	5
INSTALLATION	7
RECEIVING & INSPECTION.....	7
MOUNTING.....	8
Recommendations.....	8
Mechanical Dimensions.....	9
INTERFACE	11
ELECTRICAL INTERFACE.....	11
General.....	11
I/O Signal Interface.....	11
Input Lines.....	11
Drive Select 0-3.....	12
Motor On.....	12
Direction Select.....	15
Step.....	15
Write Data.....	15
Write Gate.....	16
Side Select.....	16
Output Lines.....	16
Index.....	16
Track 00.....	17
Write Protect.....	17
Read Data.....	17
PHYSICAL INTERFACE.....	18
Connectors and Cables.....	18
I/O Signals (P1/J1).....	18
Power (P2/J2).....	20
Terminator.....	20
Frame Ground.....	20
Addressing.....	22
OPERATION	23
INSERTING DISKETTE.....	23
PROPER DISKETTE USE.....	24
WRITE PROTECTION.....	24

	PAGE
MAINTENANCE	25
GENERAL.....	25
MAINTENANCE TOOLS AND EQUIPMENT.....	25
CHECKS AND ALIGNMENTS.....	26
Spindle Drive Belt Tension.....	26
Rotational Speed.....	27
Write Protect Sensor.....	29
Track 00 Sensor.....	30
Index Sensor.....	32
Media Guide Rails.....	34
R/W Heads Radial Positioning.....	37
R/W Head Azimuth.....	40
REMOVAL AND REPLACEMENT PROCEDURES.....	43
Protecting the R/W Head Surfaces.....	43
Drive Belt and Spindle Drive Motor.....	44
Printed Circuit Board.....	46
Front Bezel Assembly.....	47
Handle Assembly.....	49
Handle Shaft Support.....	50
Carrier Assembly.....	51
Right Media Guide.....	53
Left Media Guide.....	53
Index Sensor.....	56
Write Protect Sensor.....	57
Track 00 Sensor.....	58
Steel Belt Assembly.....	59
Stepper Motor.....	63
R/W Head Carriage Assembly.....	64
TROUBLESHOOTING	67
GENERAL	67
DEFINITION OF FUNCTIONAL ERROR TERMS.....	67
Seek Error.....	67
Read Error.....	67
Write Error.....	67
TROUBLESHOOTING TECHNIQUE.....	67
TROUBLESHOOTING FLOWCHARTS.....	68
RECOMMENDED SPARE PARTS	77
ILLUSTRATED PARTS LISTS	79
FINAL ASSEMBLY.....	80
CARRIER ASSEMBLY.....	82
MEDIA GUIDE FRAME ASSEMBLY.....	84
DIAGRAMS	87
INDEX	I-1

LIST OF FIGURES

FIGURE	PAGE
1 QumeTrak 142.....	3
2 Soft Sectored Format, FM.....	4
3 Soft Sectored Format, MFM.....	5
4 Unpacking the Disk Drive.....	7
5 Disk Drive Orientation.....	8
6 QumeTrak 142 Dimensions.....	9
7 Mounting QumeTrak 142 with Adapter Brackets.....	10
8 Recommended Controller Interface Circuit.....	11
9 Interface Connections.....	13
10 Control and Data Timing Requirements.....	14
11 Step Timing.....	15
12 Write Data Timing for Frequency Modulation (FM).....	15
13 Write Data Timing for Modified Frequency Modulation (MFM).....	16
14 Index Timing.....	16
15 Read Data Timing for Frequency Modulation (FM).....	17
16 Read Data Timing for Modified Frequency Modulation (MFM).....	17
17 Interface Connection.....	18
18 Connector J1 Dimensions (component side).....	18
19 Connector J2.....	20
20 PCB Connector, Jumper and Test Point Locations.....	21
21 Inserting a Diskette.....	23
22 Identification of 40 Track Diskette.....	24
23 Drive Belt Tension Adjustment.....	26
24 Rotational Speed Adjustment.....	28
25 Track 00 Sensor Adjustment.....	31
26 Index Burst Timing.....	33
27 Index Sensor Adjustment.....	33
28 Media Guides Alignment.....	35
29 R/W Head Radial Alignment.....	38
30 Stepper Motor Adjustment.....	39
31 Azimuth Check.....	42
32 Protecting the R/W Head Surfaces.....	43
33 Spindle Drive Motor Removal.....	44
34 Releasing Contacts from Connector Body.....	45
35 Front Bezel and Handle Assembly Removal.....	47
36 Carrier Assembly Removal.....	51
37 Left Media Guide Removal.....	54
38 Index Sensor Removal.....	56
39 Track 00 Sensor Removal.....	58
40 Steel Belt Removal.....	59
41 Steel Belt Replacement.....	60
42 Aligning Steel Belt Hole and Pulley Thread.....	61
43 R/W Head Carriage Free Movement Test.....	62
44 Stepper Motor Removal.....	63
45 R/W Head Carriage Removal.....	65
46 Basic Subroutine Troubleshooting Flowchart.....	69
47 Seek Error Troubleshooting Flowchart.....	71
48 Read Error Troubleshooting Flowchart.....	73
49 Write Error Troubleshooting Flowchart.....	75

LIST OF FIGURES, cont.

	PAGE
Final Assembly.....	81
Carrier Assembly.....	83
Media Guide Frame Assembly.....	85
PCB Component Location Diagram.....	88
Schematic Diagram, sheet 1.....	89
Schematic Diagram, sheet 2.....	91

LIST OF TABLES

TABLE		PAGE
1	Performance Specifications.....	2
2	Reliability Specifications.....	2
3	Installation Requirements.....	8
4	Drive Select.....	12
5	I/O Signal Connector P1 Requirements.....	19
6	I/O Signal Connector P1/J1 Pin Assignments.....	19
7	Power Connector P2/J2 Requirements.....	20
8	Frame Ground Requirements.....	21
9	Maintenance Tools.....	25
10	Recommended Spare Parts.....	77

INTRODUCTION

SCOPE OF MANUAL

This manual provides information concerning the operation and maintenance of the QumeTrak 142 Flexible Disk Drive. The manual is divided into the following sections: Introduction, Installation, Interface, Operation, Maintenance, Troubleshooting, Recommended Spare Parts, Illustrated Parts Lists, and Diagrams.

GENERAL DESCRIPTION

The QumeTrak 142 Flexible Disk Drive is an advanced design that is based on Qume's manufacturing experience with its standard size flexible disk drive models. Qume's proven design head carriage assembly and ceramic read/write (R/W) head with tunnel erase are employed for long media life. Efficient access time (12ms track-to-track) is assured through a highly accurate and reliable steel band type head positioning mechanism. Media rotation is belt driven from a DC spindle drive motor, eliminating the need for AC power to the unit. This drive provides a low cost, direct access, 48 TPI track density data storage device for soft sectored flexible (floppy) diskettes.

The QumeTrak 142 provides unformatted storage capacity of 250k bytes on single density or 500k bytes on double density two-sided flexible diskettes.

The QumeTrak 142 is a half-height design. When two QumeTrak 142 drives are stacked, each drive occupies exactly one-half the installation height (1.625 inches) of a standard 5.25 inch drive.

Standard features include:

- Only positive DC power required (no AC or negative DC);
- Low heat dissipation;
- Industry standard interface;
- Four drive daisy chain capability;
- Internal write protect circuitry;
- In Use LED activity indicator on the front bezel.

OPTIONS

A Full Height (for 3.312 inch cutout) and a Two Thirds Height (for 2.209 inch cutout) front bezel are available as options for the QumeTrak 142. These bezels facilitate mounting of a single 142 drive in the standard cutout space for a full height drive or for a two thirds height drive, respectively. For specific dimensions refer to the QumeTrak 142 Dimensions illustration.

Track-to-track access capability of 6ms is also an available optional configuration of the QumeTrak 142. This reduction of the standard 12ms track-to-track access time requirement is achieved by a high performance stepper motor.

SPECIFICATIONS SUMMARY

Table 1 Performance Specifications

	SINGLE DENSITY	DOUBLE DENSITY
CAPACITY PER DISKETTE		
UNFORMATTED	250k bytes	500k bytes
FORMATTED	163k bytes (128 bytes × 16)	327k bytes (256 bytes × 16)
RECORDING DENSITY (TRACK 39)	2938 BPI	5876 BPI
TRACK DENSITY	48 TPI	48 TPI
NUMBER OF CYLINDERS	40	40
NUMBER OF TRACKS	80	80
RECORDING METHOD	FM	MFM
ROTATIONAL SPEED	300 RPM	300 RPM
TRANSFER RATE	125k bits/sec	250k bits/sec
LATENCY (AVERAGE)	100 ms	100 ms
ACCESS TIME		
AVERAGE	160 ms	160 ms
TRACK-TO-TRACK	12 ms (6 ms optional)	12 ms (6ms optional)
SETTLING	15 ms	15 ms
MOTOR START TIME	0.5 sec	0.5 sec

Table 2 Reliability Specifications

ERROR RATES	
SOFT ERROR RATE	ONE ERROR PER 10 ⁹ BITS READ
HARD ERROR RATE	ONE ERROR PER 10 ¹² BITS READ
SEEK ERROR RATE	ONE ERROR PER 10 ⁶ SEEKS
MTBF	8000 POH UNDER TYPICAL USAGE (25% DUTY CYCLE)
MTTR	30 MINUTES
COMPONENT LIFE	5 YEARS
MEDIA LIFE	3 × 10 ⁶ PASSES/TRACK 30,000 INSERTIONS

COMPATIBILITY

The QumeTrak 142 uses as the storage media ANSI standard, soft sectored, two-sided, 5.25 inch flexible read/write (R/W) diskettes, that are equivalent to Qume's P.N. 51200-01 certified media.

The QumeTrak 142 model disk drive complies with American National Standards Institute (ANSI) interfacing specifications for 5.25 inch flexible disk drives and features industry standard interface.

WARRANTY, SERVICE AND TRAINING**WARRANTY AND SERVICE**

The basic Qume service policy, terms, conditions and prices for repairs will be specifically described in the Memory Products Service and Spares Catalog, publication number 37052. For specific warranty details refer to your QumeTrak 142 purchase contract.

TRAINING

Qume offers depot service training on the QumeTrak 142 disk drive. These regularly scheduled classes, to be held at Qume's Hayward, California facility, will cover mechanical and electronic theory of operation, field and service depot level troubleshooting, subassembly removal and replacement procedures, mechanical and electronic adjustments and service checks, and preventive maintenance. Detailed information on customer training classes will be contained in the Memory Products Service and Spares Catalog, publication number 37052.

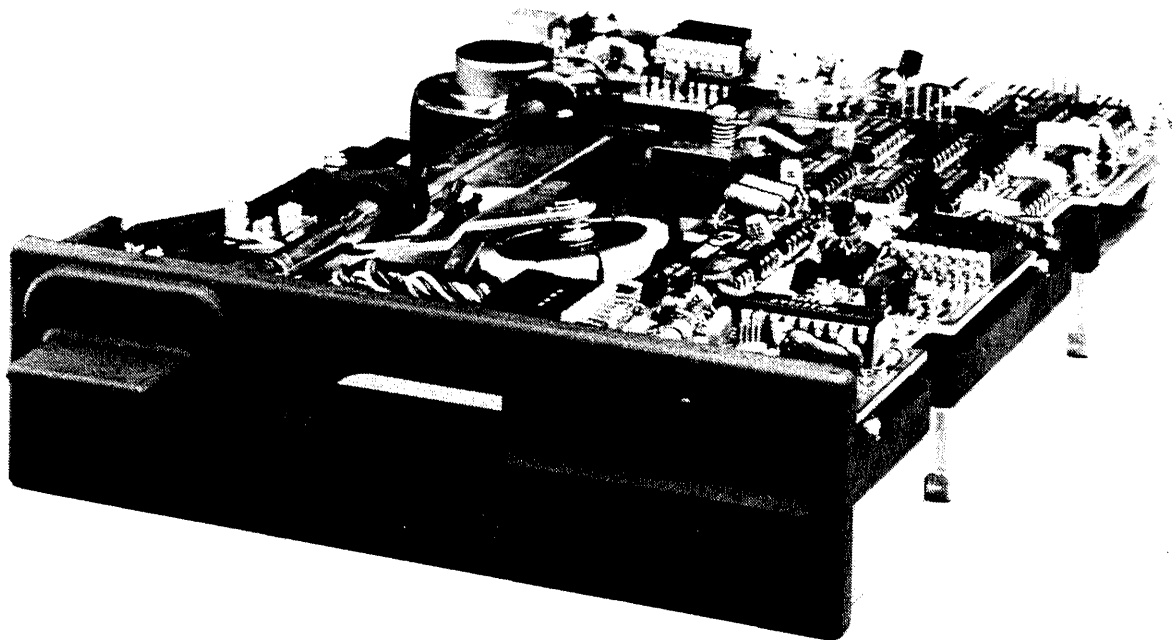

0137

Figure 1 QumeTrak 142

FM RECORDING FORMAT

The data format is totally a function of the host system. The FM Format figure shows the recommended soft sectored format using Frequency Modulation (FM). The format described is similar to the IBM format with the inter-sector gaps G1, G3, and G4 shortened. All drive tolerances have been accommodated in developing this format.

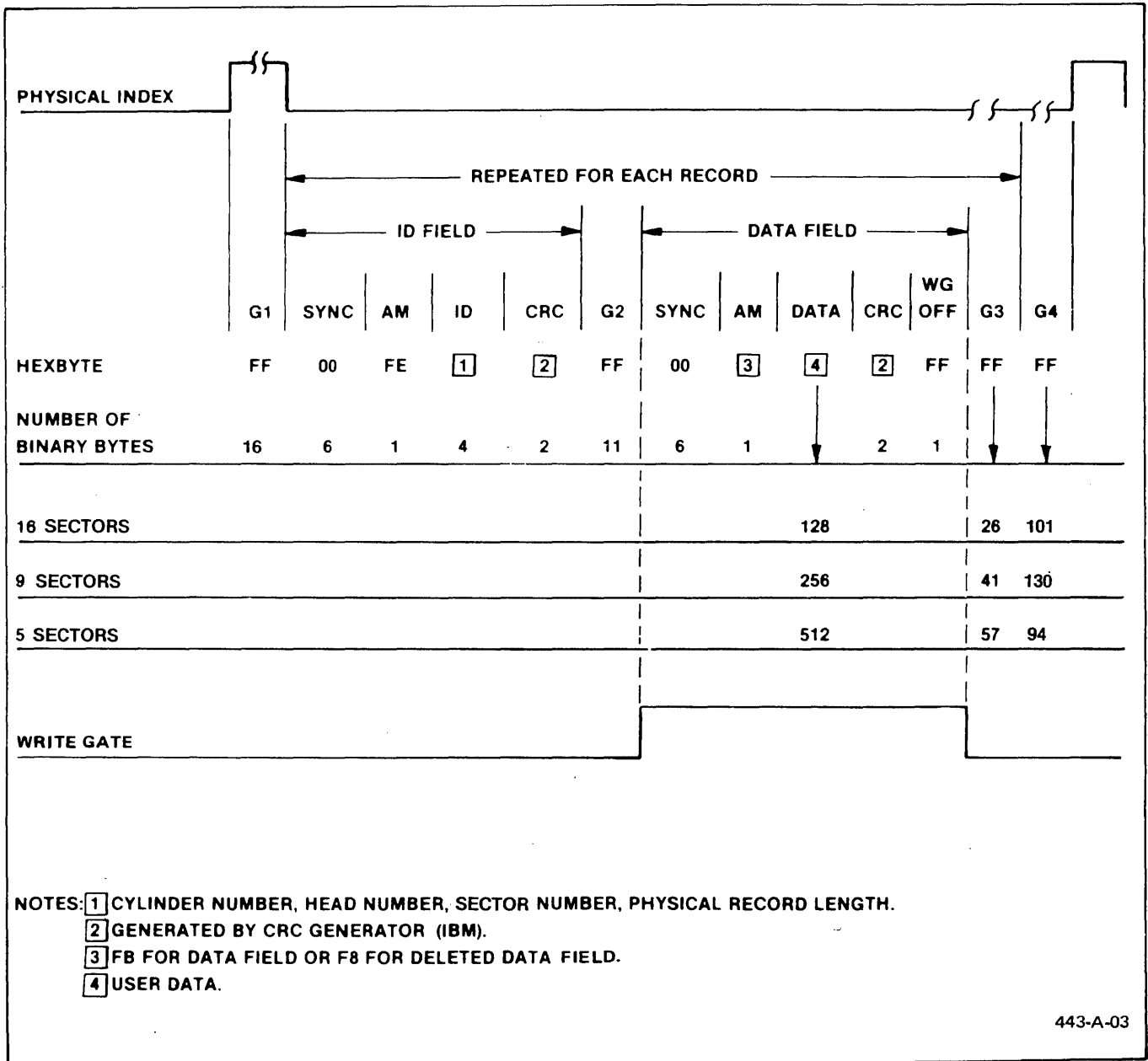

Figure 2 Soft Sectored Format, FM

MFM RECORDING FORMAT

The data format for Modified Frequency Modulation (MFM) is also totally a function of the host system. The MFM Format figure shows the recommended soft sectored format using MFM. The format described is similar to the IBM double density format with the inter-sector gaps G1 and G4 shortened. All drive tolerances have been accommodated in developing this format.

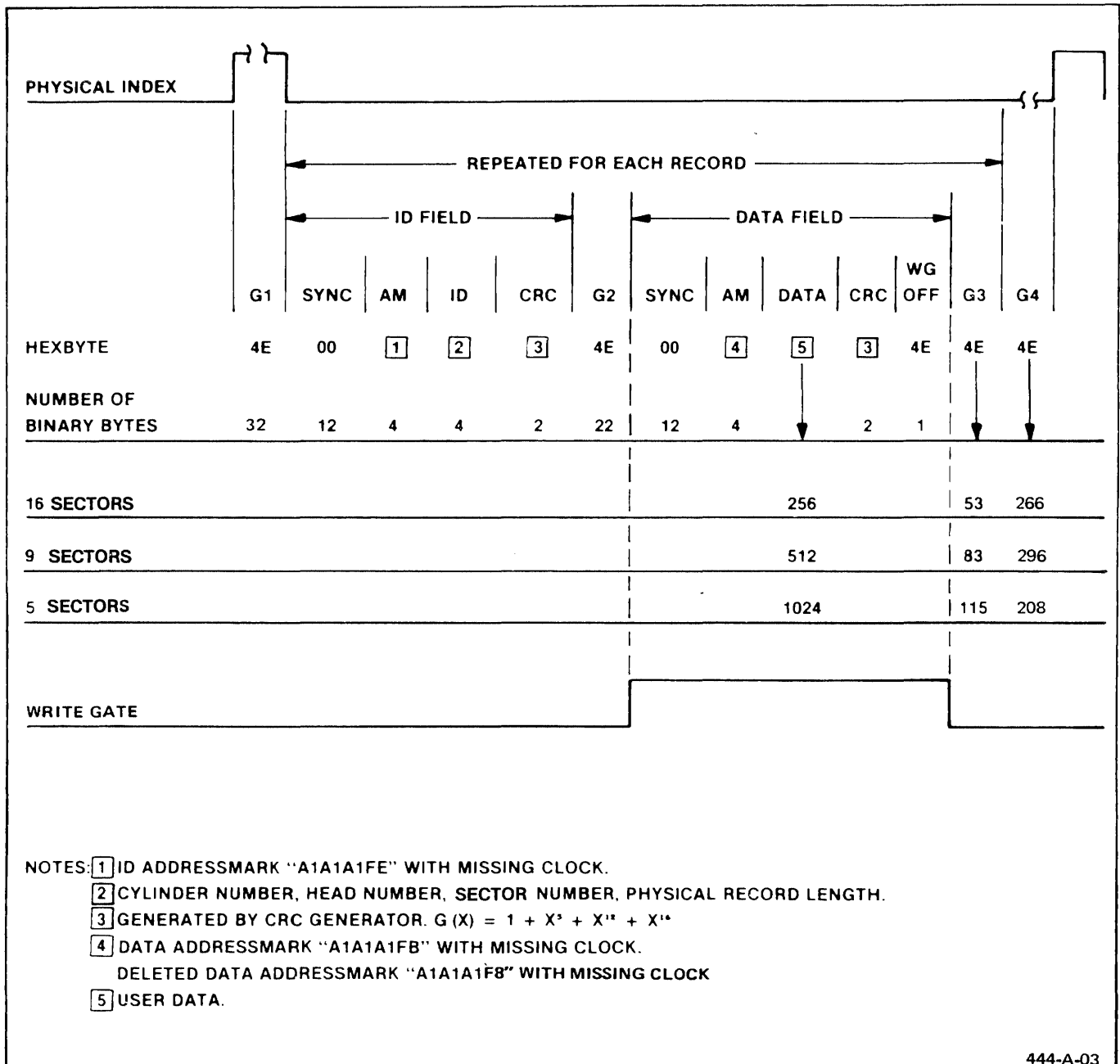

Figure 3 Soft Sectored Format, MFM

INSTALLATION

RECEIVING AND INSPECTION

Each disk drive is carefully packaged for adequate protection during shipment. Unpack and inspect the disk drive as follows:

1. Inspect the shipping container for any signs of damage. If damage is observed, have the delivery agent note the damage on the shipping document. Some shippers may wish to be present when the container is opened if external damage is apparent.
2. Open the container and unpack the disk drive as illustrated.
3. Turn the Handle on the front bezel one quarter turn clockwise to horizontal position and pull the cardboard shipping insert from the diskette slot in the front bezel.

CAUTION

Do not turn the Handle to vertical position unless a diskette or the cardboard shipping insert is in place in the drive as instructed. This may cause damage to the R/W heads.

4. Retain all packaging materials for possible reshipment.
5. Inspect the disk drive for loose or damaged parts, or other signs of damage. Note any evidence of such damage on the invoice and file a claim with the carrier immediately if the condition of the unit so warrants.
6. If damage that might impair drive operation is detected, do not attempt to operate the disk drive. Contact Qume for advice and instructions.
7. If the drive will not be used for some time, it is advisable to replace the cardboard insert after completing inspection.
8. When repacking the disk drive for shipment or storage, use only the original packaging materials.

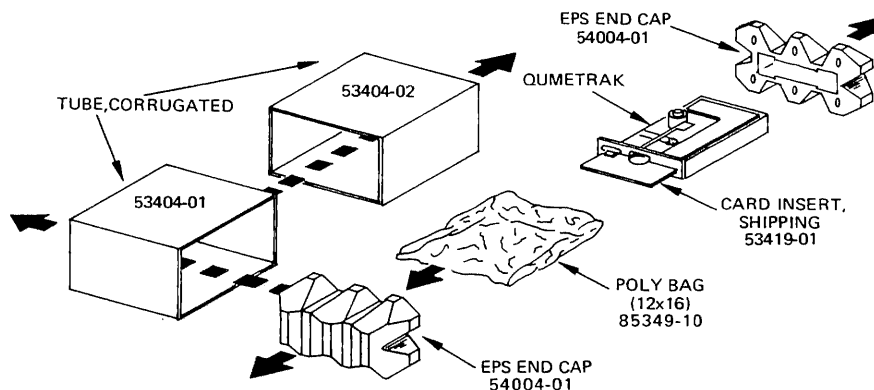

197-B-02

Figure 4 Unpacking the Disk Drive

INSTALLATION

MOUNTING

RECOMMENDATIONS

The QumeTrak 142 can be mounted in any of three positions: for horizontal or vertical front loading, or for vertical top loading. When the drive is mounted in horizontal front loading position, it must be positioned with the **printed circuit board facing up**.

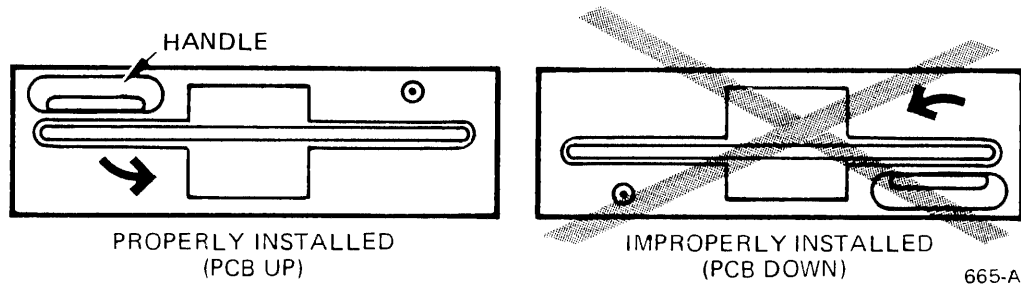

665-A

Figure 5 Disk Drive Orientation

Table 3 Installation Requirements

DC POWER REQUIREMENTS (AT DC POWER CONNECTOR J2)	VOLTAGE	MAX RIPPLE	CURRENT
	+12VDC \pm 5% +5VDC \pm 5%	100MV P-P 50MV P-P	0.8A TYPICAL 0.6A TYPICAL
POWER DISSIPATION	CONTINUOUS: 12.6W STANDBY: 3.5W		TYPICAL TYPICAL
ENVIRONMENT		OPERATING	STORAGE*
	TEMPERATURE	+5°C TO +43°C (41°F TO 110°F)	-10°C TO +45°C (14°F TO 113°F)
	RELATIVE HUMIDITY	20 TO 80%	8 TO 80%
	MAXIMUM WET BULB	+29°C (84°F)	NO CONDENSATION
MECHANICAL DIMENSIONS (EXCLUSIVE OF FRONT BEZEL)	WIDTH	146.0 mm (5.75 in.)	
	HEIGHT	40.5 mm (1.59 in.)	
	DEPTH	203.2 mm (8.0 in.)	
	WEIGHT	0.9 Kg. (2.0 lbs.)	
MOUNTING POSITIONS	HORIZONTAL FRONT LOAD (PCB SIDE UP ONLY), VERTICAL FRONT LOAD, VERTICAL TOP LOAD.		
* IN QUME SHIPPING CONTAINER.			

679-A-01

MECHANICAL DIMENSIONS

The mounting and clearance dimensions of the QumeTrak 142 are as shown in the Dimensions illustration. Verify proper mounting locations before installing a drive.

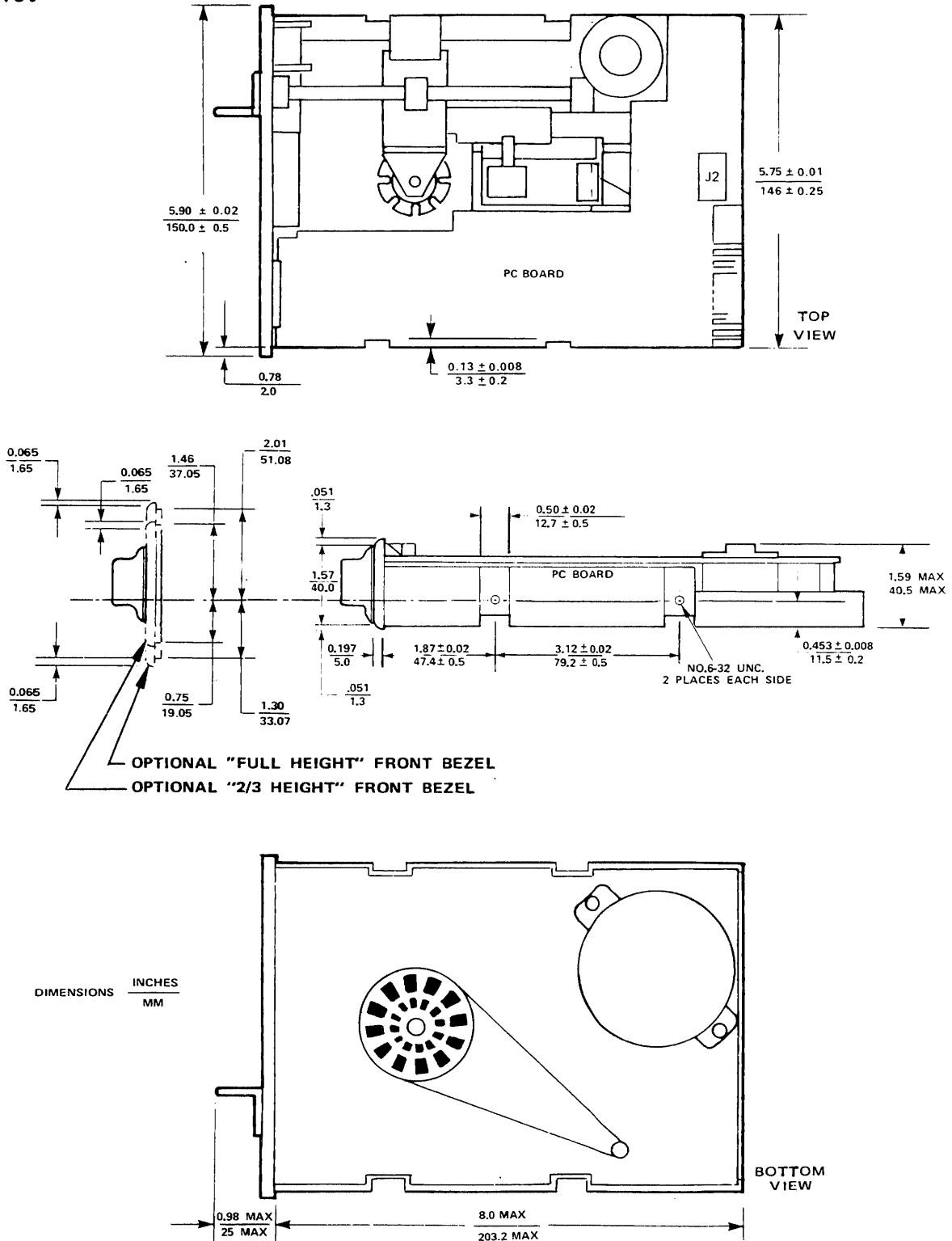
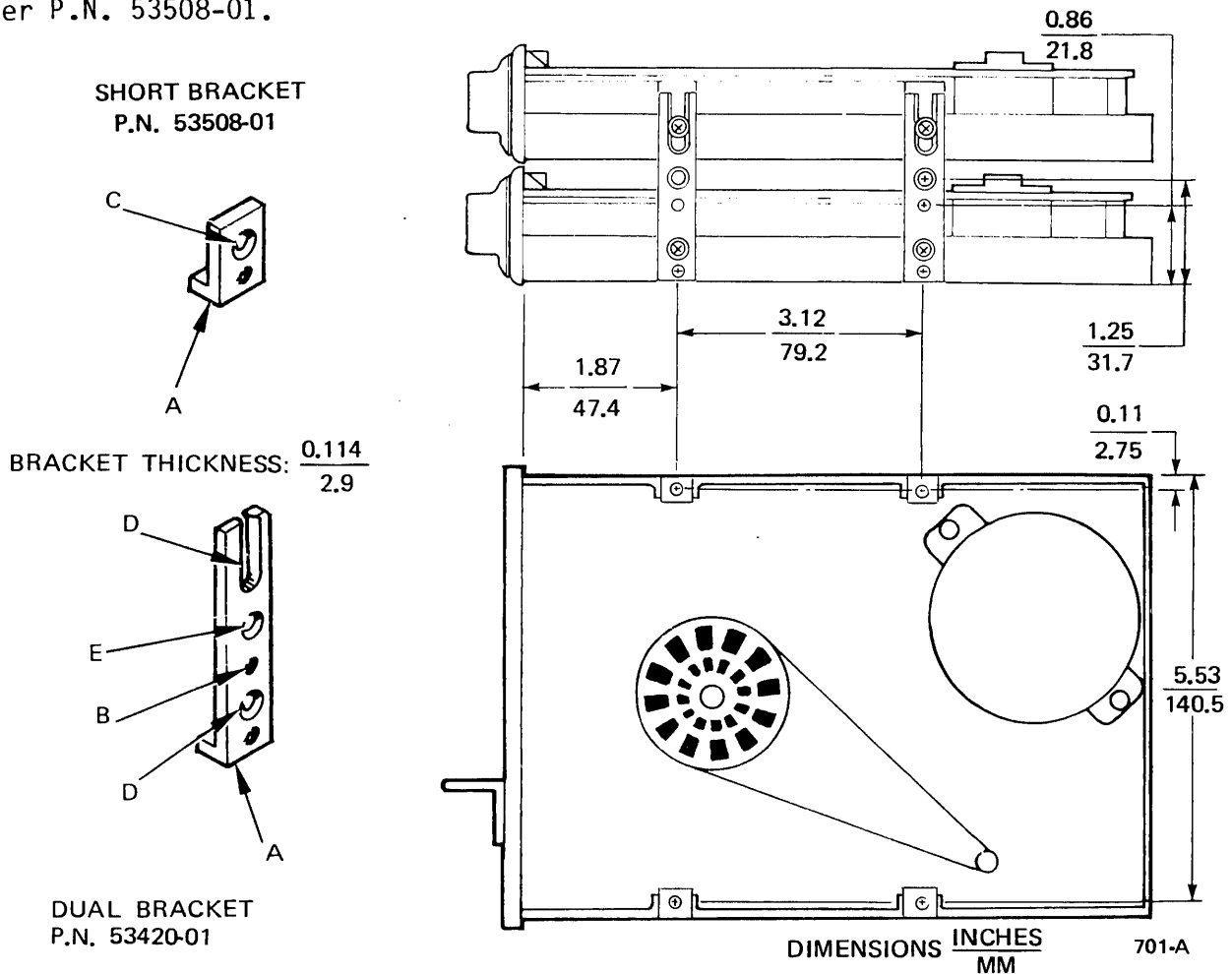

Figure 6 QumeTrak 142 Dimensions

704-A-01

INSTALLATION

For mounting the QumeTrak 142 drive, two 6-32 threads are provided on each side as shown in the Dimensions illustration. If it is desired to mount a single drive from the bottom, adapter brackets are required. A short adapter bracket with a 6-32 thread in the bottom and a 0.16 inch countersunk hole that lines up with the 6-32 thread in the side of the drive is available from Qume under P.N. 53508-01.



LOCATION:

- A = 6-32 THREAD FOR BOTTOM MOUNTING (SCREW TIP MAY PROTRUDE BRACKET BY MAX. 0.12 IN.) IN ANSI SPEC. LOCATION FOR FULL HEIGHT DRIVE;
- B = 6-32 THREAD FOR SIDE MOUNTING (SCREW TIP MUST NOT PROTRUDE BRACKET) IN ANSI SPEC. LOCATION FOR FULL HEIGHT DRIVE;
- C = 4.2 mm (0.16 IN.) THRU HOLE, COUNTERSUNK FOR MOUNTING BRACKET TO ONE HALF HEIGHT DRIVE;
- D = 4.2 mm (0.16 IN.) THRU HOLE & SLOT, COUNTERSUNK FOR STACK MOUNTING TWO HALF HEIGHT DRIVES;
- E = 4.2 mm (0.16 IN.) THRU HOLE, COUNTERSUNK FOR MOUNTING BRACKET TO ONE HALF HEIGHT DRIVE WITH FULL HEIGHT BEZEL.

Figure 7 Mounting QumeTrak 142 with Adapter Brackets

Two QumeTrak 142 drives may be mounted in the space occupied by one full height standard 5.25 inch drive. The two drives may be stacked using optional brackets as illustrated. The dual bracket, Qume P.N. 53420-01, has mounting holes which correspond to the locations of the side and bottom mounting holes on a standard full height drive.

INTERFACE

ELECTRICAL INTERFACE

GENERAL

The QumeTrak 142 has two interface connectors. Connector P1/J1 interfaces digital I/O signals, and connector P2/J2 interfaces the +5V and +12V DC power sources. The Interface Connections illustration and the Connectors and Cables paragraph identify the pin assignments for these connectors.

I/O SIGNAL INTERFACE

All I/O signal interface lines are TTL compatible and are active (true) when low. The disk drive uses 7438 NAND buffers (open collector) as output line drivers, and TTL logic level receivers on the input lines. The input of all receiver lines in a single drive, and those in the last drive of a daisy chain, are terminated in 150 Ohms pulled up to +5 Volts (refer to the Terminator paragraph).

The recommended controller interface circuit is shown in the following diagram.

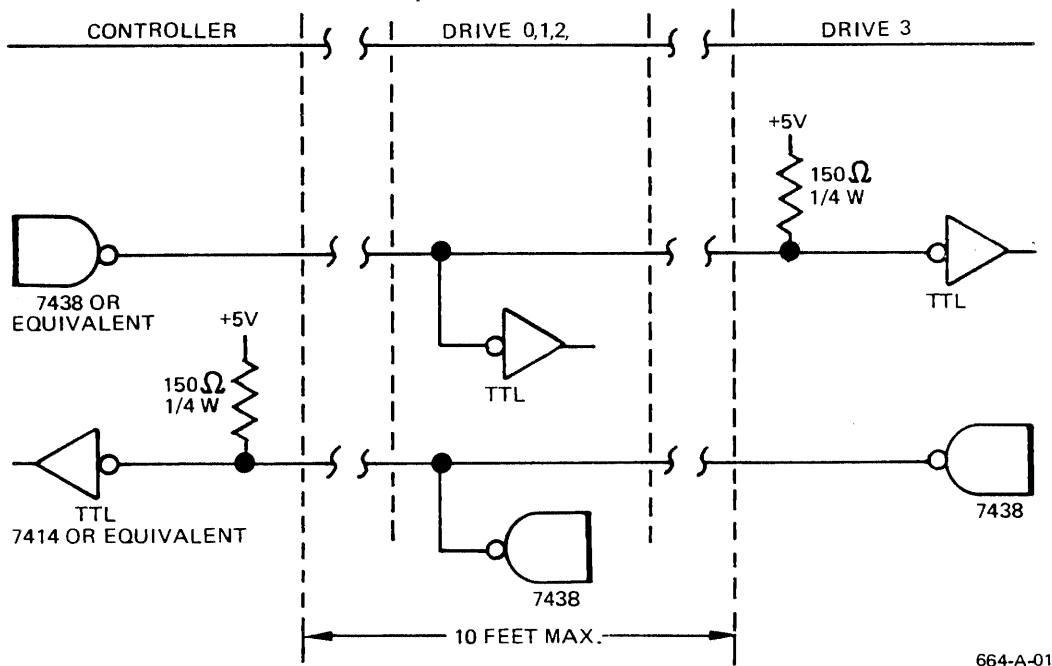

Figure 8 Recommended Controller Interface Circuit

INPUT LINES

There are ten active low TTL input lines to the QumeTrak 142. Individual signal line characteristics are as follows:

High Level:	2.4 to 5.25 V (logical false);
Low Level:	0 to 0.4 V (logical true);
Input Impedance:	150 Ohms to +5 V.

Drive Select 0-3

An active low level on the appropriate Drive Select (DS) line (pin 6, 10, 12, or 14) enables communication between the individual drive and the controller.

The QumeTrak 142 is configured from the factory to operate as Drive 0 in a single drive system. However, it is easily modified by the user to operate in a multiple drive system. Four separate input lines are provided for the controller to select which drive on the interface is to be used. When two, three, or four drives are daisy-chained, each drive must have a unique DRIVE SELECT address. A drive's address is selected by pluggable jumpers DS0 through DS3. When in a drive the two pins of jumper DS0 are shorted, this drive becomes designated as Drive 0 and as such addressable by an active low signal on the DRIVE SELECT 0 line. If the two pins of jumper DS1 are shorted, Drive 1 will be activated when the DRIVE SELECT 1 line is active low. The same system applies to jumpers DS2 and DS3. Refer to the Drive Select table.

NOTE

Only one pair of jumpers can be shorted within a single drive. Each drive within a daisy chain must have a unique DRIVE SELECT number.

Table 4 Drive Select

DRIVE NUMBER	DRIVE SELECT INPUT				PLUGGABLE JUMPERS DS			
	0	1	2	3	DS0	DS1	DS2	DS3
0	L	H	H	H	S	O	O	O
1	H	L	H	H	O	S	O	O
2	H	H	L	H	O	O	S	O
3	H	H	H	L	O	O	O	S

L = LOW LEVEL, H = HIGH LEVEL, S = SHORT, O = OPEN

680-A-02

Motor On

An active low level on this line (pin 16) enables the drive motor. One-half second is required after MOTOR ON is activated for the spindle to come up to speed before reading or writing on the diskette. This line should be deactivated for maximum motor life if no commands are to be issued to the drive within two seconds (10 media revolutions) after completion of a previous command.

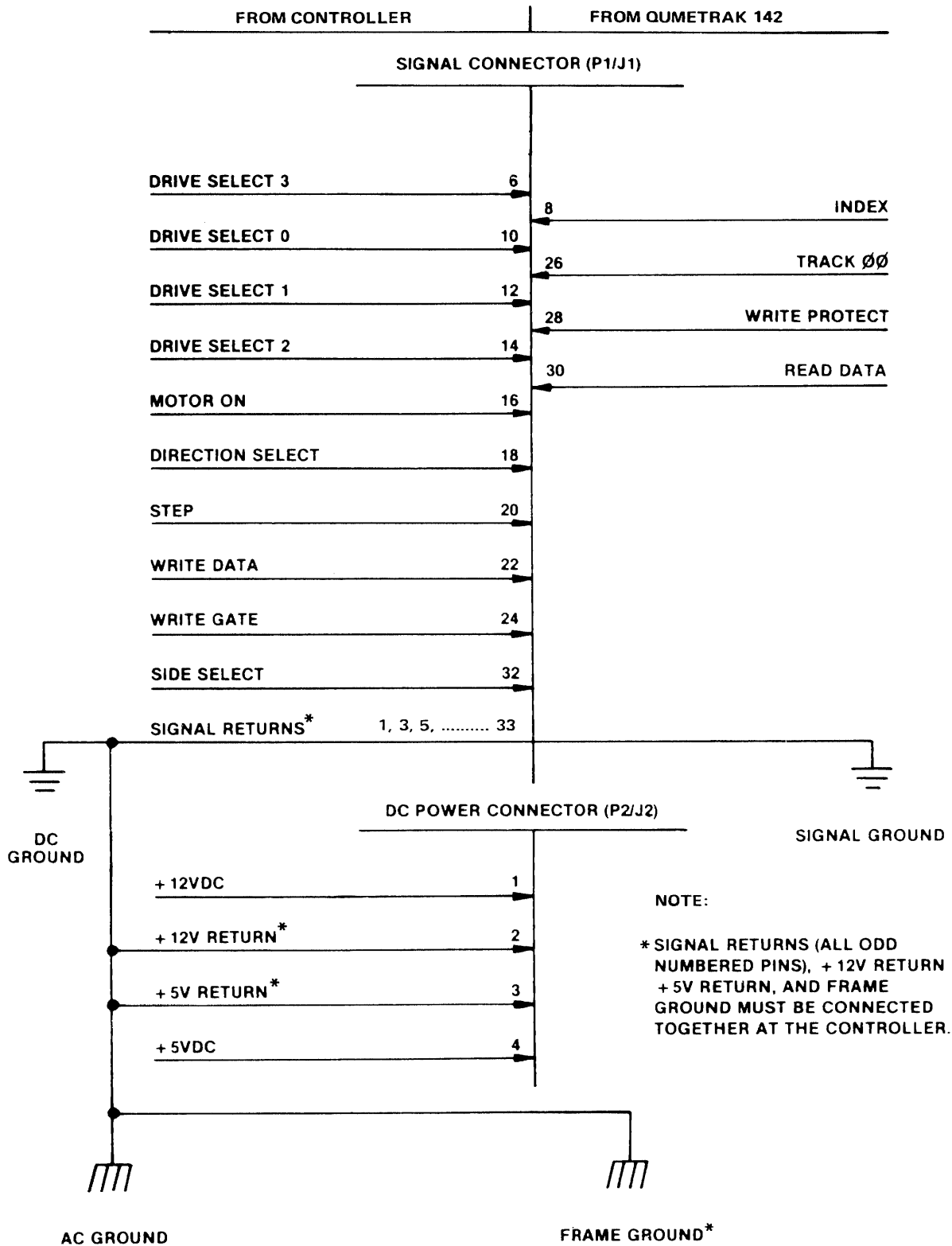

391-A-07

Figure 9 Interface Connections

INTERFACE

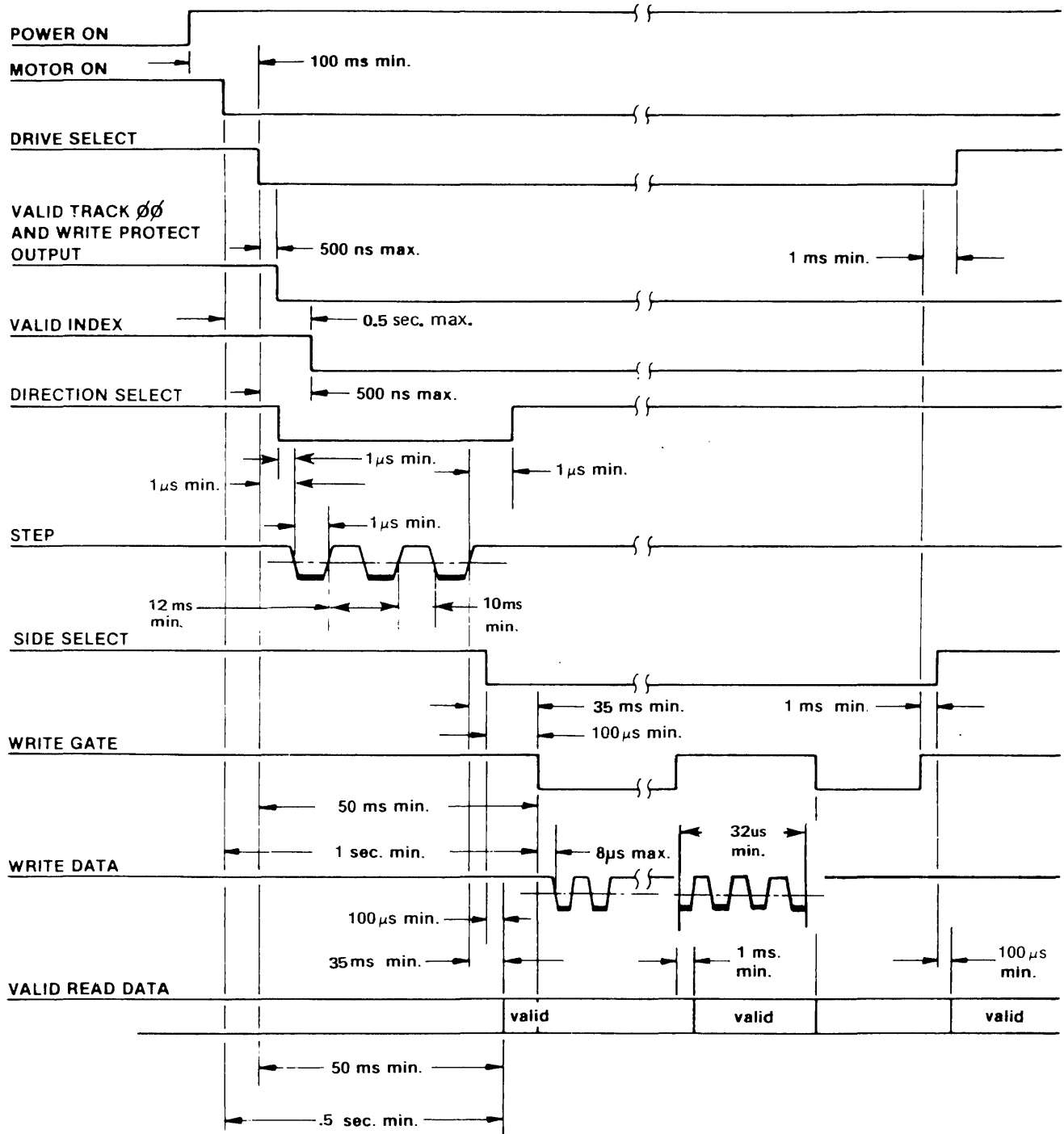

394-A-06

Figure 10 Control and Data Timing Requirements

Direction Select

DIRECTION SELECT (pin 18) defines the direction of R/W head movement. A low level on this line causes the head positioning mechanism to move the R/W head toward the center of the diskette when the STEP line is pulsed. With the DIRECTION SELECT line at a high level, a pulse on the STEP line causes the head positioning mechanism to move the R/W head away from the center of the diskette. The logic state of DIRECTION SELECT can be changed 1 microsecond after the trailing (positive going) edge of the STEP pulse, and to within 1 microsecond before the trailing edge of a following STEP pulse. The logic state of DIRECTION SELECT cannot be changed during the positive going transition of STEP, or within the 1 microsecond preceding the positive going transition of STEP.

Step

An active low pulse on this line (pin 20) causes the R/W head to be moved one track. The direction of movement is controlled by the DIRECTION SELECT line. Pulses applied to the STEP line require the following timing characteristics:

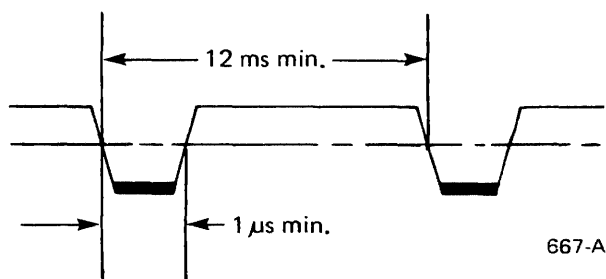

Figure 11 Step Timing

Write Data

The data to be written on the diskette arrive on this interface line (pin 22). Each transition on this line from a high level to an active low level causes the write current direction through the head to be reversed. The WRITE DATA timing characteristics for Frequency Modulation (FM) and Modified Frequency Modulation (MFM) formats are as illustrated.

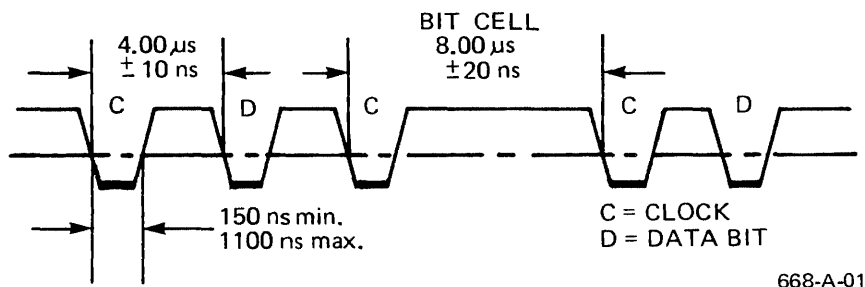

Figure 12 Write Data Timing for Frequency Modulation (FM)

INTERFACE

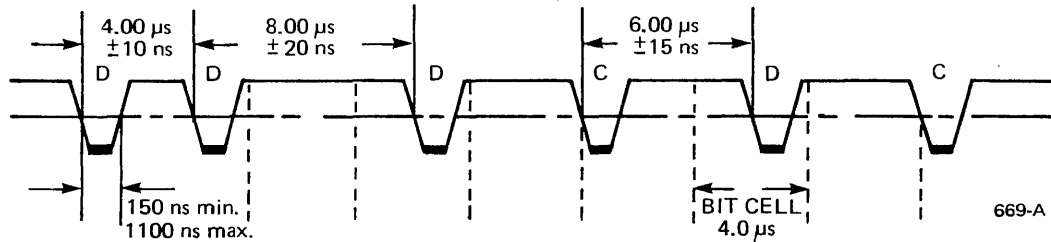

Figure 13 Write Data Timing for Modified Frequency Modulation (MFM)

Write Gate

An active low level on this line (pin 24) enables the write current source, and disables the stepping (head positioning) circuitry. A high level on this line enables the read circuitry. Deactivation of DRIVE SELECT, and/or changing SIDE SELECT must be delayed at least 1 millisecond following a write operation to assure that the track is fully tunnel erased. Refer to the Control Data Timing Requirements illustration for the timing relationships.

Side Select

SIDE SELECT defines which surface of a two-sided diskette is to be accessed for data recording or retrieval. An active low level on this line (pin 32) selects the R/W head for diskette side 1 (the diskette side facing the PCB); a high level selects the R/W head for diskette side 0 (the diskette side facing the disk drive chassis). When switching from side to side, a 100 microsecond delay is required before any read or write operation can be initiated.

OUTPUT LINES

There are four active low TTL output lines. For each the low (true) voltage level is 0 to 0.4 Volt, with a maximum sink capability of 48 milliamps when the 7438 NAND buffers draw current. The high (false) voltage level is 2.4 to 5.25 Volts, with a maximum leakage current of 250 microamps when the 7438 NAND buffers are at cutoff. The characteristics of each output line are as follows:

Index

This interface signal (pin 8) is provided by the drive once each diskette revolution. The leading (negative going) edge of the INDEX pulse indicates to the controller the beginning of a track. INDEX timing characteristics are as illustrated.

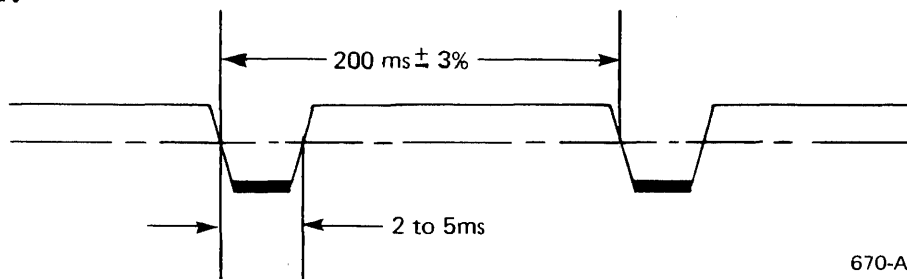

Figure 14 Index Timing

Track 00

An active low level on this line (pin 26) indicates that the R/W head is positioned at track 00.

Write Protect

An active low level on this line (pin 28) indicates to the controller that a write protected diskette, i.e. a diskette with a disable tab covering the write enable notch is loaded. The drive does inhibit writing when a write protected diskette is installed.

Read Data

Data from the diskette is output to the host system on this line (pin 30) in the same form as it was received on the WRITE DATA line. Each flux reversal that is sensed on the diskette produces a transition to an active low level on the READ DATA line, and a return to high level later. Refer to the Read Data Timing illustrations for FM and MFM timing characteristics.

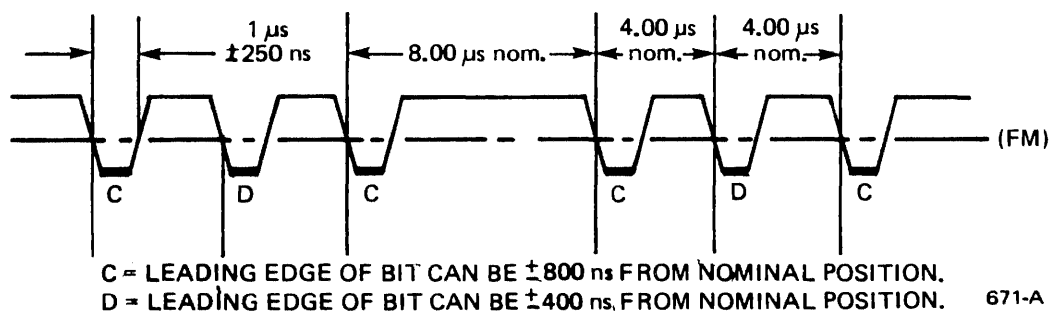

Figure 15 Read Data Timing for Frequency Modulation (FM)

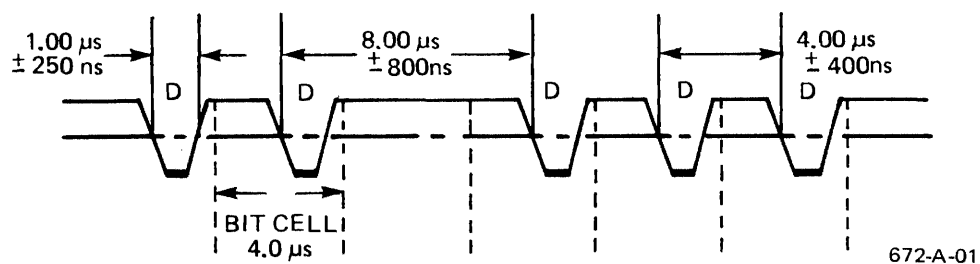

Figure 16 Read Data Timing for Modified Frequency Modulation (MFM)

INTERFACE

PHYSICAL INTERFACE

The physical interface between the QumeTrak 142 and the host system is via two connectors: I/O signals on P1/J1 and DC power on P2/J2; a fast-on terminal tab provides for frame ground interconnection. The Interface Connection illustration shows how four drives would be daisy-chained to the host system (drives #1 and #2 have been deleted for clarity).

Refer to the Connectors and Cables paragraph for specific pin assignments.

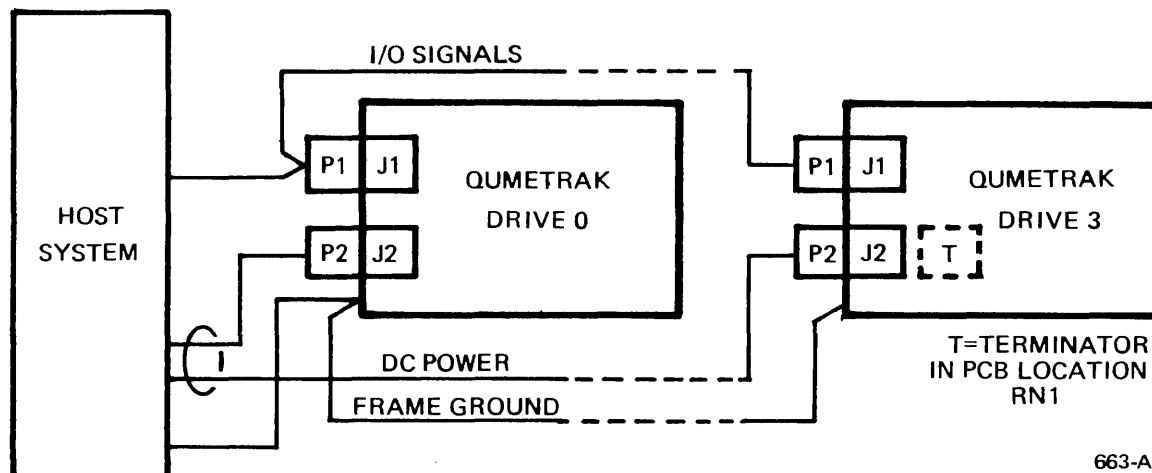

Figure 17 Interface Connection

CONNECTORS AND CABLES

I/O Signals (P1/J1)

I/O signal interfacing occurs through 34 pin PCB card-edge connector J1. The dimensions for this connector are shown in the illustration below.

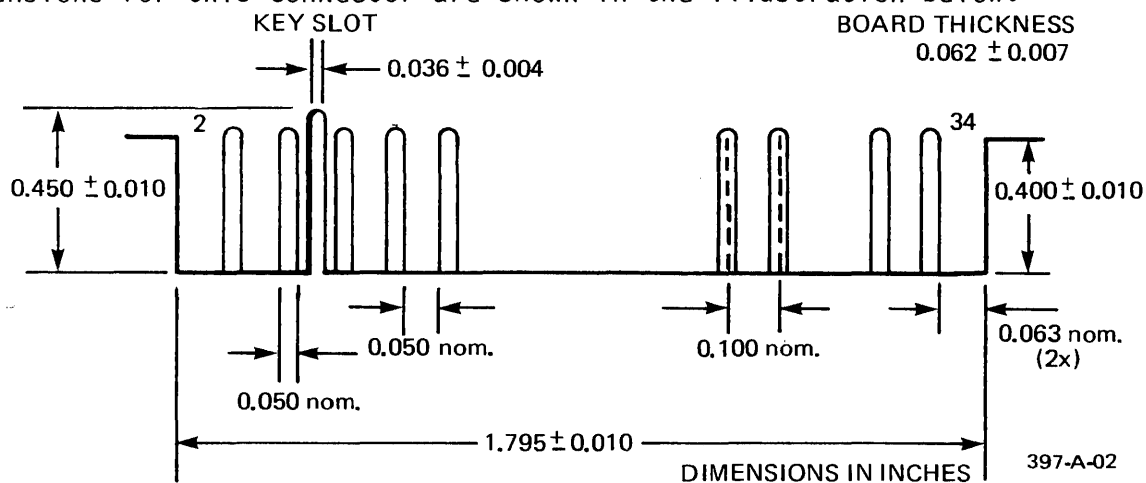

Figure 18 Connector J1 Dimensions (Component Side)

Connector P1 can be for flat cable or for twisted wire pairs. The respective I/O connector requirements and pin assignments are as tabulated.

Table 5 I/O Signal Connector P1 Requirements

PARTS	FOR FLAT CABLE	FOR TWISTED WIRE PAIRS	
	3M P/N	CRIMP TYPE	SOLDER TYPE
		AMP P/N	AMP P/N
CONNECTOR	3463-0001	_____	_____
HOUSING	_____	583717-5	583717-5
CONTACT	_____	1-583616-1	583854-3
POLARIZING KEY	3439-0000	583274-1	583274-1
CRIMP TOOL	_____	90268-1	_____
PRESS	3440	_____	_____
LOCATOR PLATE	3443-11	_____	_____
PLATEN	3442-3	_____	_____
EXTRACTOR TOOL	_____	91073-1	91073-1
CABLE	_____	_____	_____
FLAT CABLE (10 FEET MAX.)	3365-34	_____	_____
TWIST PAIR (10 FEET MAX)	_____	AWG 26	AWG 26

677-A

Table 6 I/O Signal Connector P1/J1 Pin Assignments

RETURN PIN NO.	SIGNAL PIN NO.	SIGNAL NAME (STANDARD)	RETURN PIN NO.	SIGNAL PIN NO.	SIGNAL NAME (STANDARD)
1	2	N/A	19	20	STEP
3	4	N/A	21	22	WRITE DATA
5	6	DRIVE SELECT 3	23	24	WRITE GATE
7	8	INDEX	25	26	TRACK 00
9	10	DRIVE SELECT 0	27	28	WRITE PROTECT
11	12	DRIVE SELECT 1	29	30	READ DATA
13	14	DRIVE SELECT 2	31	32	SIDE SELECT
15	16	MOTOR ON	33	34	N/A
17	18	DIRECTION SELECT	—	—	_____

681-A

INTERFACE

Power (P2/J2)

DC power is interfaced through connector P2/J2. The power cable requirements and connector pin assignments are as tabulated.

Table 7 Power Connector P2/J2 Requirements and Pin Assignments

CONNECTOR REQUIREMENTS			PIN ASSIGNMENTS	
PARTS	P2 (CABLE SIDE) AMP P/N	J2 (DRIVE SIDE) AMP P/N	PIN NO.	SIGNAL NAME
HOUSING	1-480424-0	641737-1	1	+ 12VDC
CONTACT (4 PINS)	60169-1	_____	2	+ 12V RETURN
CRIMP TOOL	90124-2	_____	3	+ 5V RETURN
EXTRACTOR TOOL	1-305183-1	_____	4	+ 5VDC
CABLE (10 FEET MAX)	AWG 18	_____	—	_____

682-A-01

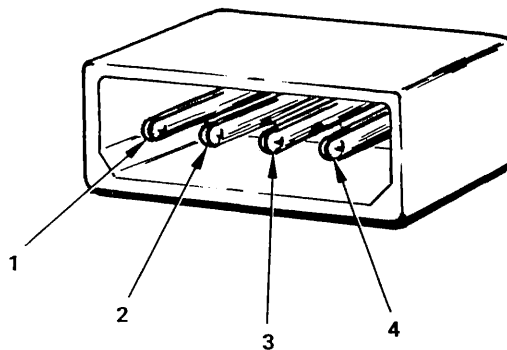

676-A

Figure 19 Connector J2

TERMINATOR

The input line terminator is a 150 Ohm DIP resistor module which is at the factory plugged into the DIP socket, location RN1, on the PCB. This terminator must be present in a single drive, or in the last drive of a daisy chain.

CAUTION

All other drives in a daisy chain should have terminator resistors removed for reliable functioning of the drive and avoiding possible damage to the controller circuit.

FRAME GROUND

The frame of the QumeTrak 142 must be grounded to the controller to ensure proper operation and low noise susceptibility. The system frame ground wire should be connected to the disk drive frame. A fast-on tab is provided on the drive for this purpose.

Table 8 Frame Ground Requirements

FAST-ON TAB	MATING CONNECTOR
AMP P/N 60920-1	AMP P/N 60972-1

683-A

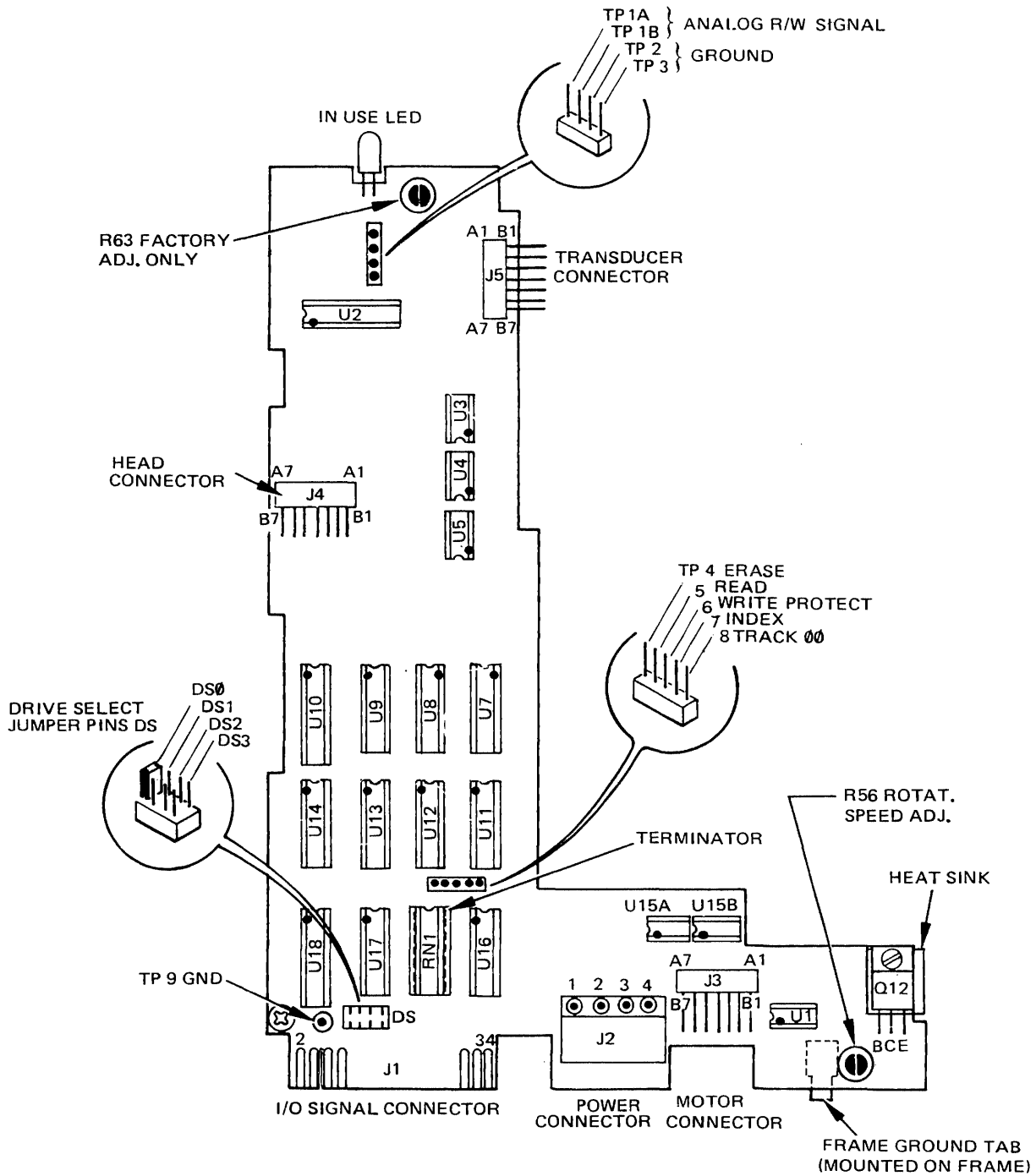

Figure 20 Connector, Jumper & Test Point Locations

080-C-02

INTERFACE

ADDRESSING

Four pairs of jumperable pins, DS0 through DS3 are provided to permit individual addressing of a drive with the corresponding Drive Select signal. These pins are located on the disk drive's PC Board between the I/O signal card-edge connector J1 and IC location U17.

To properly enable the address line of a single drive or of the first drive in a daisy chain, one jumper is to be installed across pins DS0 (see also the Terminator paragraph). The second drive in a daisy chain needs one jumper across pins DS1 for proper addressability. The third and fourth drive in a daisy chain become selectable with one jumper installed across pins DS2 or DS3, respectively.

Only one DS jumper must be installed in any individual disk drive to ensure unique addressing.

DS line addressing always selects side 0 by default. To select side 1, the SIDE SELECT line must be pulled low as well.

OPERATION

INSERTING DISKETTE

Insert the R/W diskette into the drive, head access slot first and with the diskette label facing the side with the In Use LED and the Handle on the drive's front bezel. The diskette must be fully inserted so that it rests against the stop in the back of the slot.

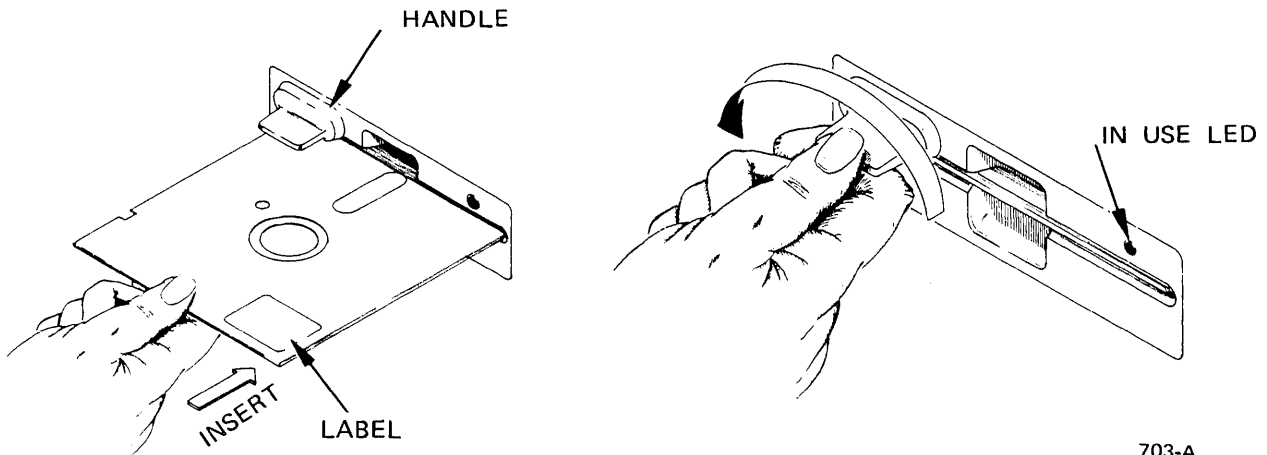

Figure 21 Inserting a Diskette

Turn the Handle one quarter turn counter-clockwise to vertical position across the diskette loading slot. The diskette is now mounted properly in the drive. An ongoing read/write (R/W) operation will be indicated by illumination of the In Use LED in the drive's front bezel.

CAUTION

Do not turn the Handle to vertical position unless a diskette (or the cardboard shipping insert) is in place in the drive as instructed. This may cause damage to the R/W heads.

A diskette may be removed from the drive only while the In Use LED is not illuminated and after the Handle has been turned one quarter turn clockwise to horizontal position so that it clears the diskette loading slot.

CAUTION

Do not attempt to turn the Handle or to remove the diskette while the In Use LED in the front bezel is illuminated. This may destroy the data on the diskette.

OPERATION

PROPER DISKETTE USE

An ANSI standard 5.25 inch diskette that is equivalent to Qume's P.N. 51200-01 certified media is recommended for use in the QumeTrak 142 disk drive. Ensure that only soft sectored 40 track capacity diskettes are being used in the drive. Attempting to use 35 track capacity diskettes in the drive may result in serious R/W head damage due to the reduced length of the head access slot (see Diskette Identification illustration).

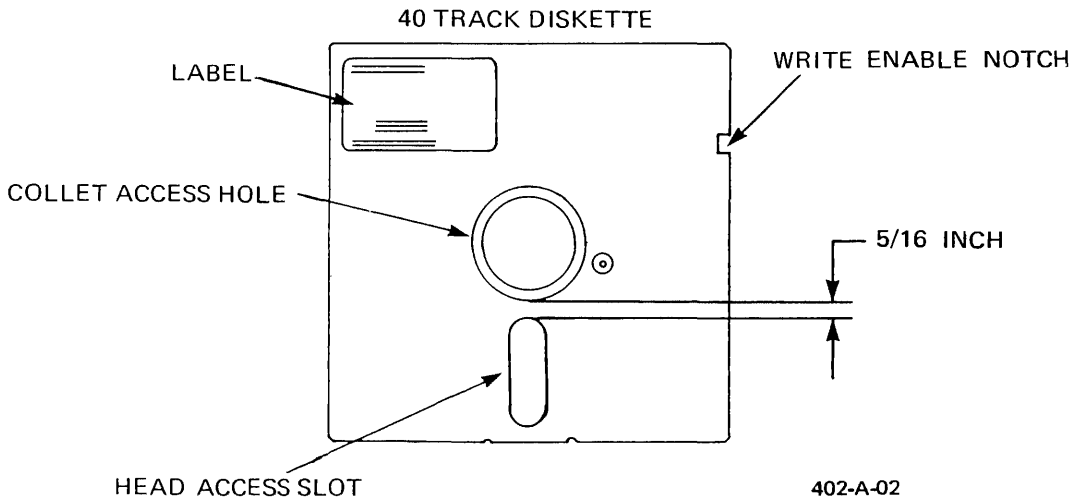

Figure 22 Identification of 40 Track Diskette

The 40 track diskette to be used in the QumeTrak 142 can be easily identified by noting the measurement between the collet access hole and the inner end of the head access slot in the diskette sleeve (refer to the Diskette Identification illustration). For 40 track diskettes this distance is $5/16$ inch. It is advisable that double sided R/W certified diskettes only are used in the QumeTrak 142.

Use top quality diskettes only. Lower grade diskettes may typically cause excessive R/W head wear, resulting in reduced R/W head life.

Handle diskettes with care. Never bring a magnetic diskette near a magnetic field or touch the diskette surface exposed by the head access slot. Protect the diskette from dust, dirt, direct sunlight and temperatures outside the manufacturer recommended safe range. Avoid bending, creasing, or writing on the diskette sleeve with pencil or ball point pen.

WRITE PROTECTION

Standard 5.25 inch diameter diskettes have a Write Enable Notch cut out of the edge on one side of their sleeve. The QumeTrak 142 drive is equipped with a write protect sensor that detects presence of the write notch and enables data to be written onto the diskette. If the write notch is missing or covered up (e. g. with a metallized sticker or tab), no data can be written onto the diskette and data already stored on it is protected from being overwritten.

MAINTENANCE

GENERAL

No maintenance should be required on the QumeTrak 142 Disk Drive under normal use and operating conditions. Clean operating site and environment, however, are extremely important for reliable performance of the drive; so is high integrity of the R/W diskettes.

Qume recommends that maintenance on the disk drive, if it becomes necessary, be performed by well qualified and properly trained technical personnel only. Proper performance of this precision product depends on the continuity of several critical factory alignments which cannot be duplicated in the field. Do not attempt repairs or alignments other than outlined in this manual.

CAUTION

The R/W head carriage assembly is factory adjusted and not field serviceable. Do not attempt any maintenance on this part; refer all head carriage maintenance to authorized personnel. Do not use cleaning diskettes or otherwise attempt to clean the R/W heads.

MAINTENANCE TOOLS AND EQUIPMENT

The tools and equipment required for various maintenance procedures are identified in the Maintenance Tools listing.

Table 9, Maintenance Tools

USE	CHECKS AND ADJUSTMENTS		DESCRIPTION
	REMOVAL AND REPLACEMENT		
		TOOL	
X	X	SCREWDRIVERS, NON MAGNETIC	#1 & 2 PHILLIPS
	X		MED. SIZE STD. FLAT
X	X	TORQUE SCREWDRIVER	LOW RANGE (<4 lb. in.) #1 PHILLIPS TIP
X		FEELER GAUGE	0.01 ± 0.001 INCH (0.265 mm) THICK, MAX. 0.16 INCH (4 mm) WIDE
X	X	CERTIFIED R/W DISKETTE	QUME P.N. 51200-01
X		CE ALIGNMENT DISKETTE	QUME P.N. 51201-01
X	X	TEST R/W DISKETTE	STD. 5.25 INCH R/W DISKETTE
X	X	MEDIA GUIDES ALIGNMENT GAUGE	QUME P.N. 53535-G1
X	X	DRIVE BELT TENSION GAUGE	QUME P.N. 53301-G1
X		DISK DRIVE EXERCISER	FOR INDIVIDUAL TRACK ACCESSING
X		OSCILLOSCOPE	DUAL TRACE
X		DC MULTIMETER	20 KOHM/VOLT OR BETTER
	X	SPRING HOOK	8 INCH (MED. SIZE, THIN)
	X	SOLDERING IRON	LOW POWER (APPROX. 20 WATT)
	X	SOLDER	ROSIN CORE, ELECTRONIC GRADE
	X	HEATSHRINK TUBING	A/R
	X	WEIGHT	50 GRAM (1.76 oz.)

CHECKS AND ALIGNMENTS

For the following service checks and alignments it is assumed that the disk drive is removed from any enclosure for good accessibility from all sides. Also, DC power and frame ground are to be applied to the unit as specified under Physical Interface in the Interface section.

Refer to the Connector, Jumper and Test Point Locations illustration for identification of PCB locations. The Illustrated Parts Lists section will be a useful reference in identifying product components.

SPINDLE DRIVE BELT TENSION

Proper tension of the spindle drive belt is somewhat critical to maintaining correct rotational speed of the magnetic media (diskette). Too taut a belt can cause a significant increase in motor start time or insufficient spindle pulley rotational speed, while too loose a belt will cause slippage, again resulting in slow spindle rotational speed.

To verify and/or adjust the spindle drive belt tension, a Drive Belt Tension Gauge (Qume P.N. 53301-G1) is required.

Check:

1. Place the drive belt tension gauge (Qume P.N. 53301-G1) into the underside of the drive **exactly** as shown in the illustration.

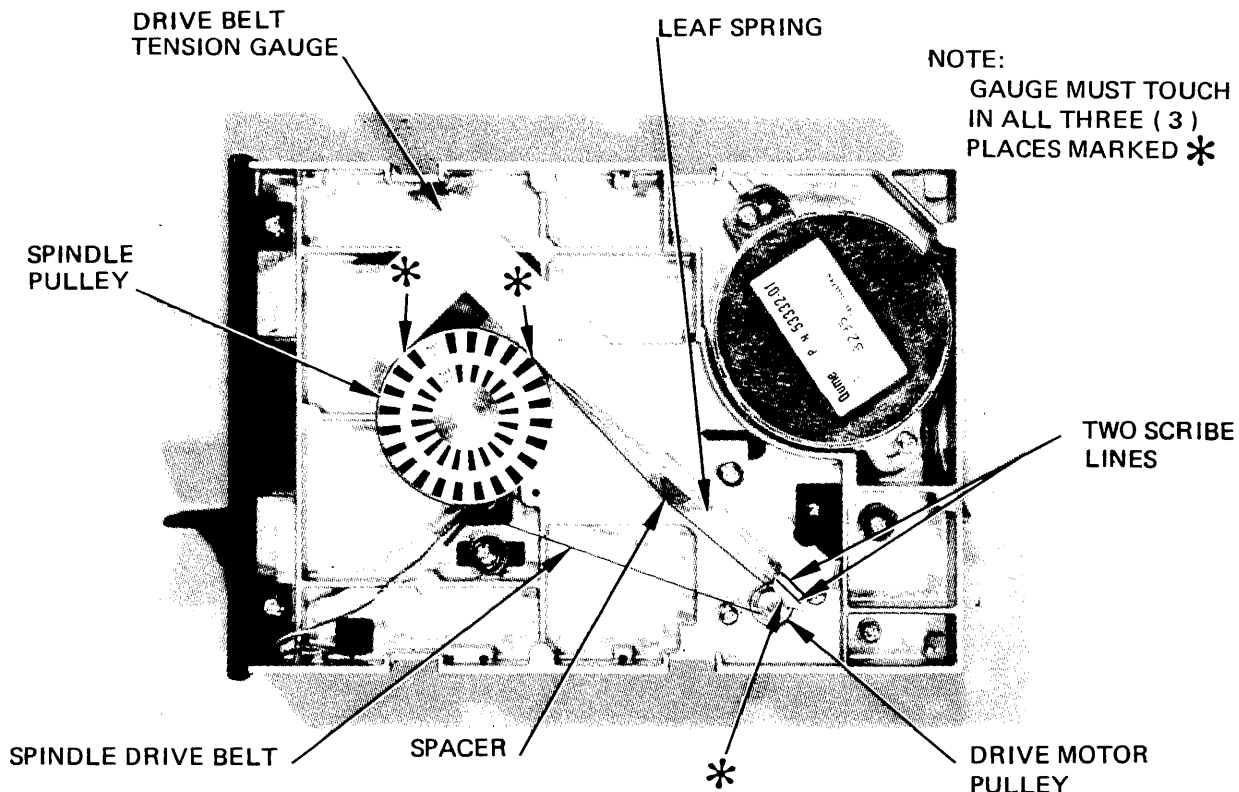

Figure 23, Drive Belt Tension Adjustment

The surfaces of the gauge's large L-shaped end must rest against the rim of the spindle pulley in two (2) locations **and** the inner face of the gauge's small L-shaped end must touch the flat surface of the small spindle drive motor pulley **between** the pulley's flanges.

Make sure that the entire width of the drive belt passes flat over the spacer on the gauge's leaf spring.

2. While holding the gauge in the above described position, read the deflection of the gauge's leaf spring pointer.

The belt tension is correct if the leaf spring tip is deflected so that it points at the area **between** the two lines scribed into the gauge near its small L-shaped end.

Alignment:

If the leaf spring tip points anywhere outside the two scribe lines on the gauge (with the gauge placed in the drive exactly as instructed above), align as outlined.

1. Loosen the two M3x0.5 mounting screws of the spindle drive motor just enough to permit repositioning of the motor.
2. Slide the motor until the correct tension is indicated by the gauge; carefully tighten the motor mounting screws and re-check the belt tension.
3. If correct belt tension cannot be obtained, the drive belt needs to be replaced.
4. Perform a Rotational Speed Check as outlined to verify correct spindle pulley rotational speed.

ROTATIONAL SPEED

Check:

Proper rotational speed of 300 RPM for the magnetic media (diskette) may be visually verified by observing the strobing effect of the black-and-white decal on the spindle pulley. The decal has two scales: a 50 Hz scale to be used under artificial lighting produced on 50 Hz AC, and a 60 Hz scale to be used under artificial lighting produced on 60 Hz AC. Check the rotational speed as follows:

1. Position the drive on its side so that the black-and-white decal on the spindle pulley can be conveniently observed.
2. Apply power to the disk drive.
3. Short pin 16 of connector J1 to ground; this should start the spindle drive motor.

4. Install a test diskette in the drive (turn Handle CCW to load R/W heads).
5. Illuminate the pulley decal with AC-powered fluorescent or neon light (incandescent light should not be used as it could produce misleading results) and observe the appropriate decal scale for the AC frequency of the light's power source. A pulley speed of 300 RPM is represented by the respective black/white decal scale pattern appearing to stand still. An apparent clockwise rotation of the pattern indicates low speed, while counterclockwise rotation represents high speed.

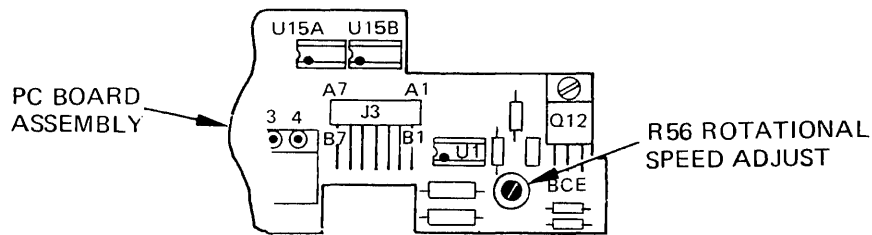

741-A

Figure 24, Rotational Speed Adjustment

Alignment:

If incorrect pulley speed is observed, and before attempting to adjust the motor speed, verify supply voltages of +5V $\pm 5\%$ and +12V $\pm 5\%$ and good drive belt integrity without slippage. Belt slippage is indicated by inconsistent rotational speed (i.e. jerking strobe pattern) with R/W heads loaded against a test diskette. In this case the drive belt tension will need to be verified and, if necessary, readjusted as outlined under Spindle Drive Belt Tension Check, or the belt may need to be replaced as outlined under Removal and Replacement Procedures.

Slow pulley speed may also be caused by improperly aligned media guide rails (excessive media friction due to warpage of the jacket, or by media binding due to insufficient line-up of collet access hole, collet, and hub). Refer to the Media Guide Rails Check and Alignment procedures for correction.

1. Perform steps 1-5 of the Check procedure above.
2. While observing the appropriate ring of the black/white decal pattern, slowly change the setting of screwdriver adjustable potentiometer R 56. Refer to the Connector, Jumper and Test Point Locations illustration to locate R 56 on the PC Board. Proper speed is attained when the decal pattern appears to be standing still.
3. Fixate the potentiometer position with a small drop of locking compound or lacquer.

WRITE PROTECT SENSOR

Check:

1. Apply power to the disk drive (verify proper supply voltages of +5V \pm 5% and +12V \pm 5%).
2. Verify that the voltage between J5-A2 and ground (TP9) is 1.0 to 1.4 Volt.
3. Without a diskette inserted into the drive, verify that the voltage between J5-A3 (or TP6) and ground (TP9) is \leq 0.4 Volt.
4. Install a test diskette without a write enable notch (or with a write protect sticker covering the notch, or turn the diskette upside-down) and verify that the voltage between J5-A3 and ground is 4.0 to 5.0 Volt.
5. If any of the above voltages cannot be verified within their given tolerances, remove and replace the left side Media Guide Assembly (with the Write Protect Sensor) as outlined in the Removal and Replacement procedures.

Alignment:

No alignment of the Write Protect sensor function is possible since it is an integral part of the left side Media Guide Assembly. Upon sensor malfunction the left side Media Guide Assembly is to be replaced as outlined.

MAINTENANCE

TRACK 00 SENSOR

Check:

This is a functional check only; an alignment check may be performed by following the alignment procedure.

1. Apply power to the disk drive (verify proper supply voltages of +5V +5% and +12V +5%).
2. Verify that the voltage between J3-A3 and ground (TP9) is 1.0 to 1.4 Volt.
3. With the Head Carriage Assembly in a position other than at track 00, verify that the voltage from J3-A4 (or TP8) to ground (TP9) is ≤0.4 Volt.
4. Move the Head Carriage Assembly to track 00 position (all the way towards the rear of the drive) so that the black tab on the left side of the carriage assembly is inserted into the slot in the track 00 sensor, and verify that the voltage between J3-A4 and ground is 4.0 to 5.0 Volt.
5. If any of the above voltages cannot be verified within the given tolerances, remove and replace the Track 00 Sensor Assembly as outlined in the Removal and Replacement procedures.

Alignment:

Adjusting the Track 00 Sensor should be attempted only after proper R/W head radial alignment has been verified as outlined under R/W Heads Radial Positioning Check.

1. Connect the disk drive to a Disk Drive Exerciser that permits selective access to specific individual tracks on a diskette installed in the drive.
2. Apply power to the disk drive and install a CE alignment diskette (Qume P.N. 51201-01).
3. Connect a sensitive multimeter between TP8 (+) and ground (TP9).
4. Select diskette side 0.
5. From the track with the radial alignment pattern (i.e. track 16 on the Qume CE alignment diskette, P.N. 51201-01) step the head carriage out to track 1 in single step increments.
6. Note the meter reading; it should be between 0.75 and 1.25 Volt.
7. Step in by one track increment to track 2 and note the meter reading to be ≤0.40 Volt.
8. Step to track 00 and note the meter reading; it should be >4.0 Volt.
9. Step in by one track to track 1; the meter reading should be between 0.75 and 1.25 Volt.

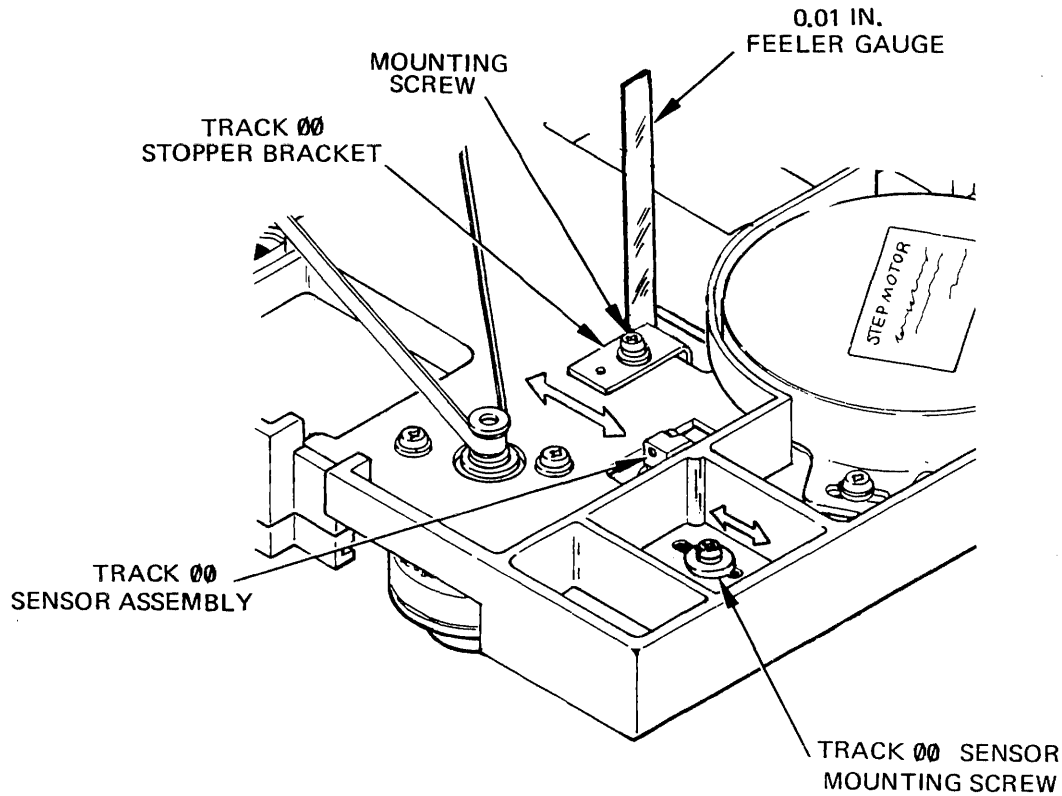

743-A

Figure 25, Track 00 Sensor Adjustment

10. If any of the conditions in steps 6 through 9 cannot be met, slightly loosen the mounting screw of the Track 00 Sensor Assembly on the underside of the drive (see Track 00 Sensor Adjustment illustration) and adjust the assembly as required (in or out) to obtain the proper voltage readings; tighten the mounting screw.
11. Verify proper alignment by seeking and verifying the head radial alignment pattern track (track 16), singlestepping from there to track 1, then stepping by one track to each side of track 1, each time returning to track 1 and verifying proper voltage readings in each case.
12. If difficulties are encountered in reaching track 00, the Track 00 Stopper bracket may be out of position.

To correct the stopper setting:

- loosen its mounting screw on the underside of the drive;
- step clearly to track 00 (verify through correct voltage readings);
- insert a 0.01 \pm 0.001 inch (0.265 mm) thick and max. 0.16 inch (4mm) wide feeler gauge between the carriage and the front of the stopper bracket and tighten the mounting screw while gently resting the front of the bracket against feeler gauge and carriage.

MAINTENANCE

INDEX SENSOR

Check:

This is a functional check only; an alignment check may be performed by following the alignment procedure.

1. Power up the disk drive (verify supply voltages of +5V +5% and +12V +5%).
2. Check that the voltage between J5-A4 and ground (TP9) is 1.0 to 1.4 Volt.
3. Without a diskette inserted into the disk drive, verify that the voltage between J5-A5 and ground (TP9) is ≤0.4 Volt.
4. Install a test diskette upside-down and verify that the voltage between J5-A5 and ground is 4.0 to 5.0 Volt.
5. If the voltage in step 2 cannot be verified within the given tolerance, remove and replace the Index Sensor Lamp as outlined in the Removal and Replacement procedures.

If the voltage in step 4 lies outside the given values, replace the Index Sensor Assembly as outlined in the Removal and Replacement procedures; after replacement, perform the Index Sensor Alignment procedure.

If the voltage in step 3 cannot be verified to within the given value, the Index Sensor Assembly may need to be aligned as outlined.

Alignment:

The Index Sensor should be aligned only after proper R/W head radial alignment has been verified as outlined under R/W Head Radial Positioning Check.

1. Connect the input probes of a dual trace oscilloscope to test points TP1A and TP1B (R/W head signals); connect scope ground to TP2 (analog ground); connect the scope trigger input to TP7 (index sensor pulse).

Select the following oscilloscope setup:

- 50 millivolt/division vertical deflection (both channels);
 - vertical input AC;
 - add channels 1 and 2;
 - 100 microseconds/division horizontal sweep;
 - external trigger source;
 - AC trigger coupling;
 - normal trigger mode;
 - trigger on the leading edge (pos.) of the index pulse.
2. Connect the disk drive to a Disk Drive Exerciser that permits selective addressing of individual specific tracks on a diskette in the drive.
 3. Apply power to the disk drive.
 4. Install a CE alignment diskette (Qume P.N. 51201-01) and select side 0.

5. Step to the track with the index burst recorded on it (i.e. track 34 on the Qume CE alignment diskette, P.N. 51201-01).
6. Observe a scope display similar to the Index Burst Timing illustration.

If the scope is triggered properly, the beginning of the index burst should occur at 400 ± 200 microseconds after the start of the sweep.

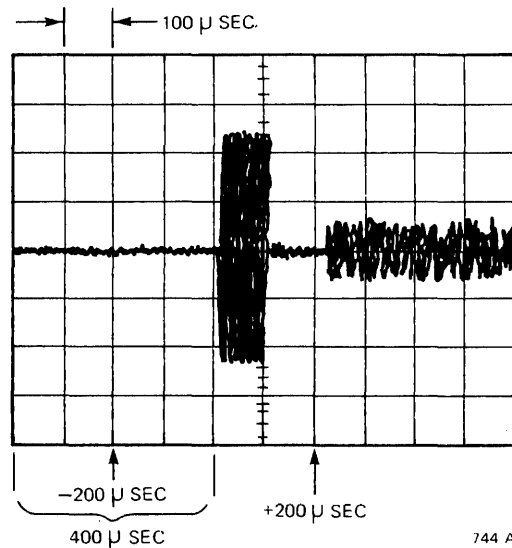

Figure 26, Index Burst Timing

7. Select diskette side 1 and note the index burst to occur at 400 ± 200 microseconds.
8. Only if the index burst timing is outside the stated tolerances, slightly loosen the index sensor mounting screw, after setting the drive on its side to gain access to the under side (refer to the Index Sensor Adjustment illustration), and change the sensor position so that the index burst occurs on both diskette sides within the stated tolerances.

Carefully tighten the sensor mounting screw and verify that the sensor position has not changed; do not exceed 3.5 lbs. in. torque on the screw (use torque screwdriver).

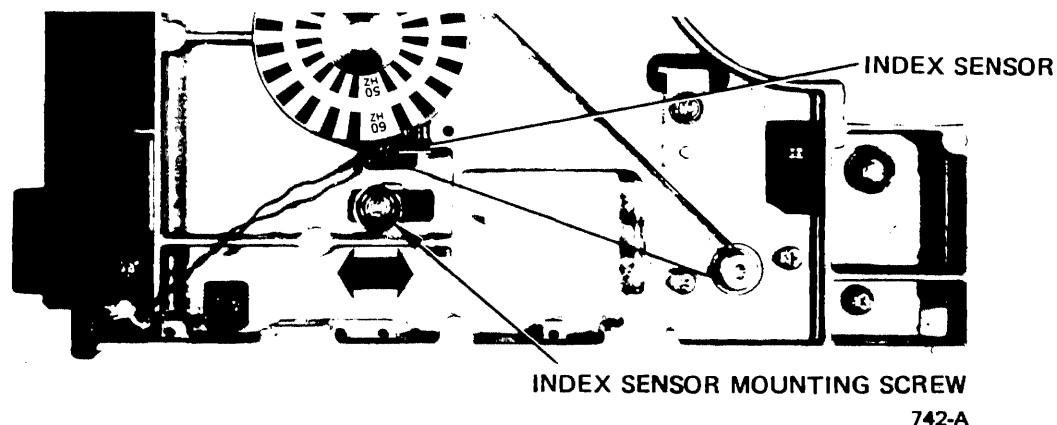

Figure 27, Index Sensor Adjustment

MAINTENANCE

MEDIA GUIDE RAILS

Media Guides Alignment Gauge (Qume P.N. 53535-G1) is required for this procedure.

Check:

An alignment check of the Left or the Right Media Guide position is not recommended, since it requires considerable disassembly and disturbs other alignments within the disk drive.

Alignment:

Alignment of the Media Guides should only be necessary when a Media Guide rail has been replaced, or if alignment was lost due to loose Media Guide mounting screws. Slow media rotational speed or difficulty in obtaining lineup reliability of media collet hole, collet, and hub when loading a diskette may be an indication of lost Media Guide alignment.

1. Remove the Printed Circuit Board (PCB) as outlined under Printed Circuit Board Removal in the Removal and Replacement Procedures section.
2. Remove the Front Bezel Assembly exactly as outlined under Front Bezel Removal in the Removal and Replacement Procedures section in order to avoid damage to the R/W Head Carriage.
3. Remove the Carrier Assembly as outlined under Carrier Assembly Removal in the Removal and Replacement Procedures section, but do not cut the index lamp wires.
4. Mark on the R/W head cables their location under the stick-on cable clamp; use a ball point pen for this.
5. Mark on the main frame casting the location of the stick-on cable clamp that retains the two R/W head cables. Use a sharp pointed pencil or scribe and outline the position of the cable clamp as close as possible so that it can be mounted back in exactly the same location.

Pry the cable clamp off the main frame casting.

6. Slide the R/W head carriage all the way towards the front of the drive (track 39 position).
7. Loosen the two mounting screws of the Right Media Guide and the remaining two mounting screws of the Left Media Guide (the Carrier Assembly mounting screws should be removed by this time).
8. Insert the Media Guides Alignment Gauge (Qume P.N. 53535-G1) into the Media Guide rails from the front of the drive.

Make sure the gauge is inserted all the way so that it rests against the spindle hub in the center and against the stepper motor pulley in the rear of the drive.

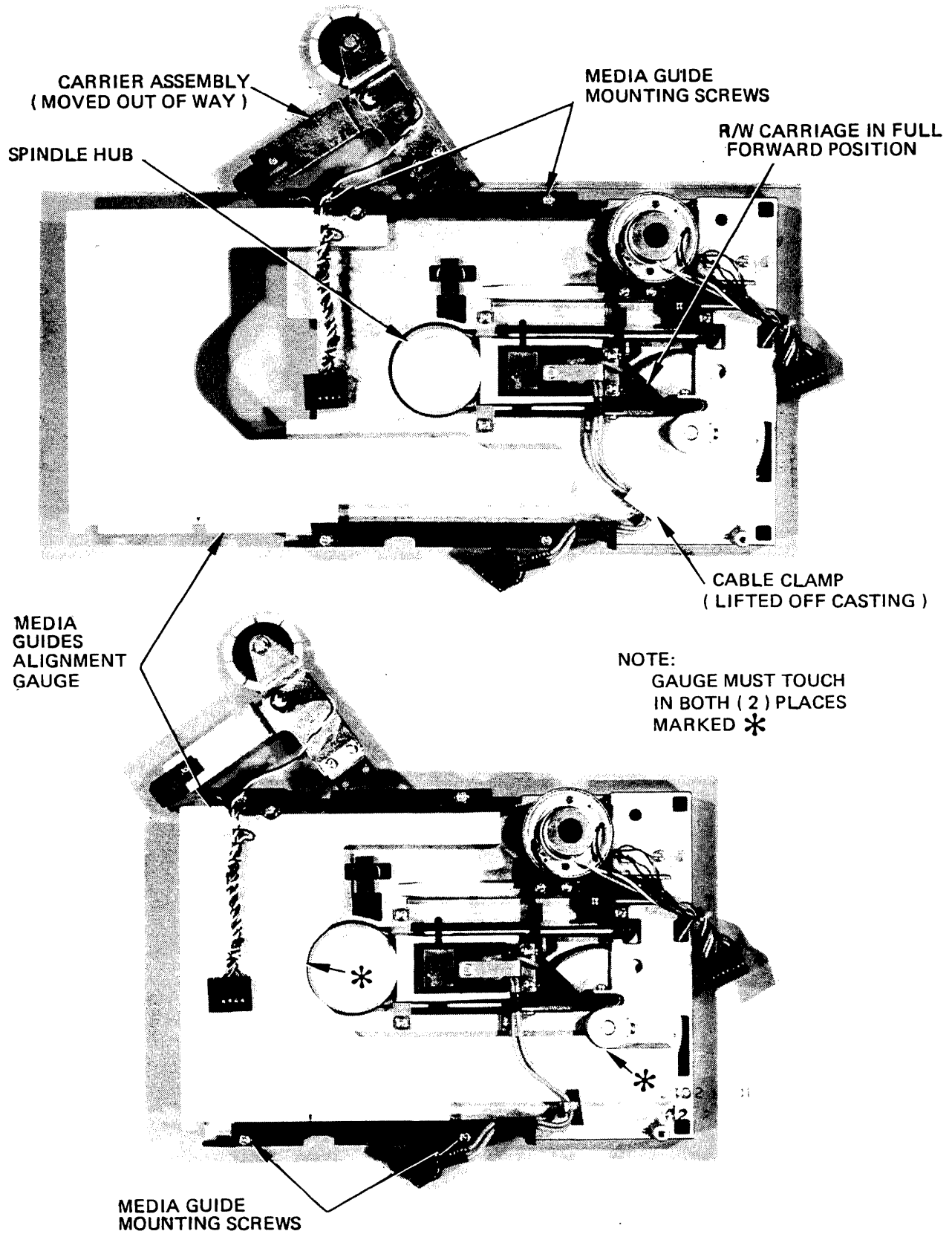

Figure 28, Media Guides Alignment

MAINTENANCE

9. While pushing both Media Guides in against the gauge, tighten all four media guide mounting screws. Make sure that the gauge is not moved but remains in "square" position, i.e. resting against spindle hub and stepper motor pulley.
10. Withdraw the gauge from the drive; it should slide out smoothly and without binding.
11. Stick the R/W head cable clamp back in its original location on the casting and return the cables to exactly the same position under the cable clamp as before.
12. Reinstall the Carrier Assembly and the Front Bezel Assembly (except for reconnecting the index lamp wires) exactly as outlined under Carrier Assembly Replacement in the Removal and Replacement Procedures section.
13. Reinstall the Printed Circuit Board as outlined in the Removal and Replacement Procedures section.
14. Perform the R/W Heads Radial Positioning Check as outlined to verify reliable track accessing.

R/W HEADS RADIAL POSITIONING

Check:

This procedure verifies precise on-track positioning of the R/W heads.

CAUTION

The R/W Head Carriage is a factory adjusted and tested assembly and is not field serviceable. Remain within the limits of the specific instructions in this manual. Do not, for any reason, attempt to make repairs or internal adjustments on this assembly, or clean the R/W heads. This can cause severe damage to the heads or to the recording media.

1. Connect the input probes of a dual trace oscilloscope to test points TP1A and TP1B (R/W head signals); connect scope ground to TP2 (analog ground); connect the scope trigger input to TP7 (index sensor).

Select the following oscilloscope setup:

- 50 millivolt/division vertical deflection (both channels);
 - vertical input AC;
 - add channels 1 and 2;
 - 20 milliseconds/division horizontal sweep;
 - external trigger source;
 - AC trigger coupling;
 - normal trigger mode;
 - trigger on the leading edge (pos.) of the index pulse.
2. Connect the disk drive to a Disk Drive Exerciser that permits selective addressing of individual specific tracks on a diskette in the drive.
 3. Apply power to the disk drive.
 4. Install a CE alignment diskette (Qume P.N. 51201-01) and select side 0.

NOTE

1. Before using the CE diskette, allow at least 30 minutes to let it reach ambient temperature in which it is to be used.
2. Qume's CE diskettes are certified at 70 \pm 5°F and 45 \pm 5% relative humidity.

5. Starting from track 00, step the head carriage "IN" on the diskette until a "cats-eye" pattern is observed on the oscilloscope as shown on the R/W Head Radial Alignment illustration. On the Qume CE alignment diskette, this pattern does appear on track 16 (otherwise set the head carriage on the closest even numbered track that affords an approximate "cats-eye" pattern). Use the trigger slope level control on the oscilloscope to synchronize the scope as necessary for a stable display.

"CATS EYE" LOBE PATTERN ON TRACK 16 USING QUME CE DISKETTE

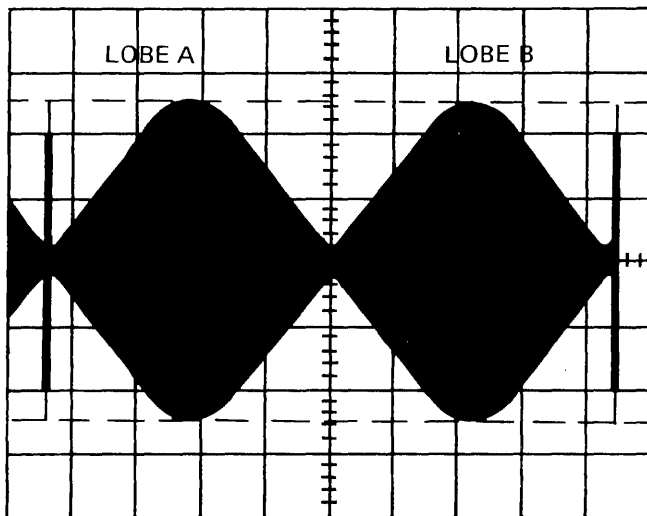

EQUAL AMPLITUDE (EXACTLY ON TRACK 16)

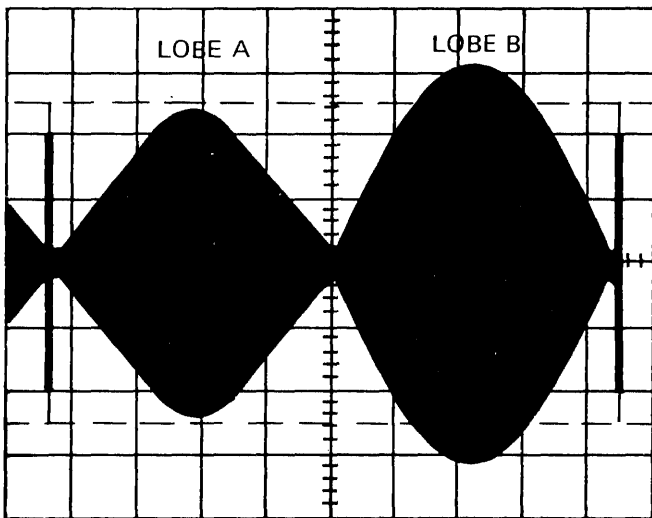

LEFT LOBE IS 70% OF RIGHT LOBE

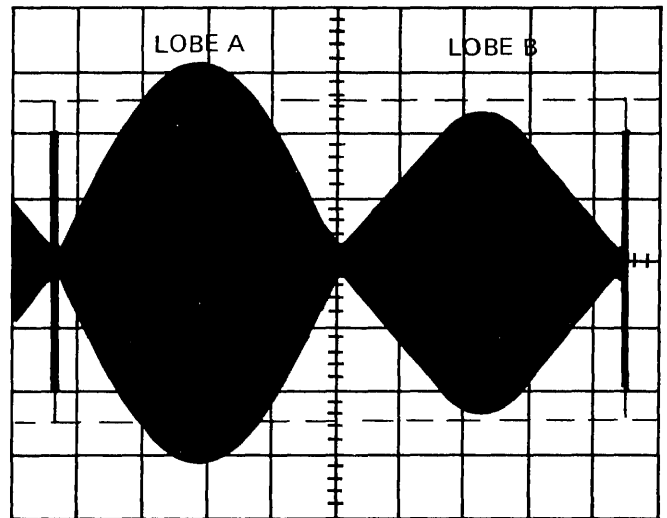

RIGHT LOBE IS 70% OF LEFT LOBE

617-A-01

Figure 29, R/W Head Radial Alignment

6. Note the relationship in amplitude between LOBES A and B.
7. Step to track 39, then "OUT" to the track with the "cats-eye" pattern; the pattern should appear on the same track number (16) as in step 5.
Note the LOBE A vs. LOBE B amplitude relationship.
8. Select diskette side 1 and repeat steps 5, 6, and 7 above. The "cats-eye" pattern must appear on the same track number as observed on side 0.
Note LOBE A vs. LOBE B amplitude relationships for both track approach directions.
9. In all above cases the amplitude relationship of LOBE A vs. LOBE B must be no less than 70%. If in any one case the amplitude of one lobe falls below 70% of the other lobe, radial positioning of the R/W heads needs to be aligned as outlined.

Alignment:

1. Perform steps 1 through 7 of the R/W Radial Positioning Check above.

NOTE

For the most precise adjustment the disk drive should be oriented in its (vertical or horizontal) "in-service" position while on the test bench. Factory alignment is performed while the drive is in horizontal position, PC Board up.

2. Return to the situation with the greatest out-of-tolerance head position.
3. Slightly loosen the two stepper motor mounting screws (see the Stepper Motor Mounting illustration) and slowly rotate the stepper motor until the LOBE A vs. LOBE B amplitude relationship is no less than the 70% tolerance.

Note the direction in which the motor is moved.

4. By alternately selecting diskette sides 0 and 1 and carefully rotating the stepper motor in small increments, balance the left lobe of R/W head 0 with the right lobe of R/W head 1 as much as possible **while still remaining within the 70% alignment specification for each side.**
5. Repeat steps 5 and 6 of the Check procedure to verify good track alignment.
6. If the R/W head radial position cannot be aligned to fall within the 70% specification, it may be advisable to replace the Head Carriage Assembly as outlined under Removal and Replacement procedures.

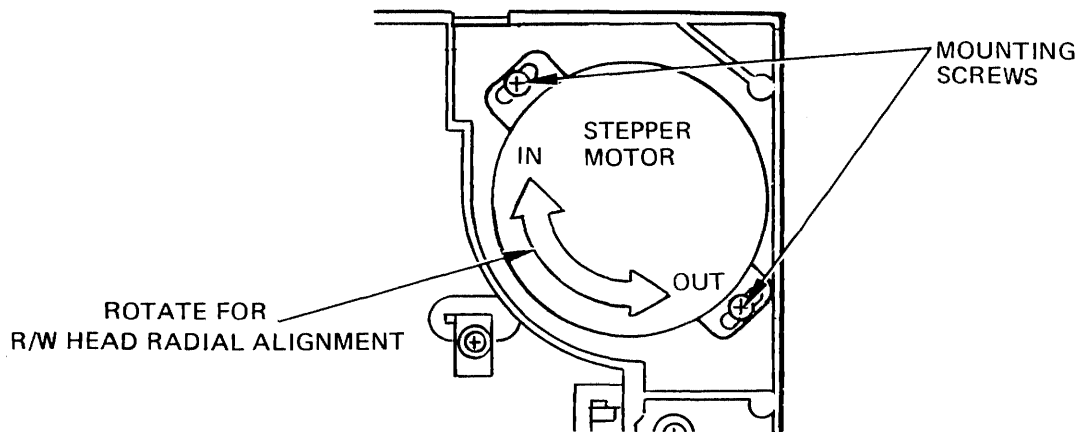

Figure 30, Stepper Motor Adjustment

R/W HEAD AZIMUTH

Check:

This check procedure is presented as a guideline for determining the degree of R/W head alignment integrity. The entire head carriage assembly is factory adjusted and tested; there is no field adjustment.

The R/W head azimuth significantly influences the signal amplitude of recorded and of read data. A head azimuth within +18 minutes of zero is acceptable, while the head carriage assembly needs to be replaced if the azimuth exceeds +18 minutes. Head azimuth cannot be adjusted.

NOTE

The head carriage assembly is factory adjusted and tested. In the field there must be no adjustment or repair attempted on the entire head carriage assembly.

1. Connect the input probes of a dual trace oscilloscope to test points TP1A and TP1B (R/W head signals); connect scope ground to TP2 (analog ground); connect the scope trigger input to TP7 (index sensor).

Select the following oscilloscope setup:

- 50 millivolt/division vertical deflection (both channels);
 - vertical input AC;
 - add channels 1 and 2;
 - 0.5 milliseconds/division horizontal sweep;
 - external trigger source;
 - AC trigger coupling;
 - normal trigger mode;
 - trigger on the leading edge (pos.) of the index pulse.
2. Connect the disk drive to a Disk Drive Exerciser that permits selective addressing of individual specific tracks on a diskette in the drive.
 3. Apply power to the disk drive.
 4. Install a CE alignment diskette (Qume P.N. 51201-01) and select diskette side 0.

NOTE

1. Before using the CE diskette, allow at least 30 minutes for the diskette to reach ambient temperature in which it is to be used.
2. Qume's CE diskettes are certified at 70 +5°F and 45 +5% relative humidity.

5. Step the head carriage to track 34 on the diskette and compare the waveform displayed on the scope to the Azimuth Check illustration.
6. Select diskette side 1 to check the second R/W head and compare the waveform displayed on the scope to the Azimuth Check illustration.
7. If the displayed waveform is not within ± 18 minutes on both sides of the diskette, the head carriage assembly needs to be replaced.

Alignment:

R/W head azimuth cannot be adjusted. If azimuth is out-of-spec, the head carriage needs to be replaced as outlined under Removal and Replacement procedures.

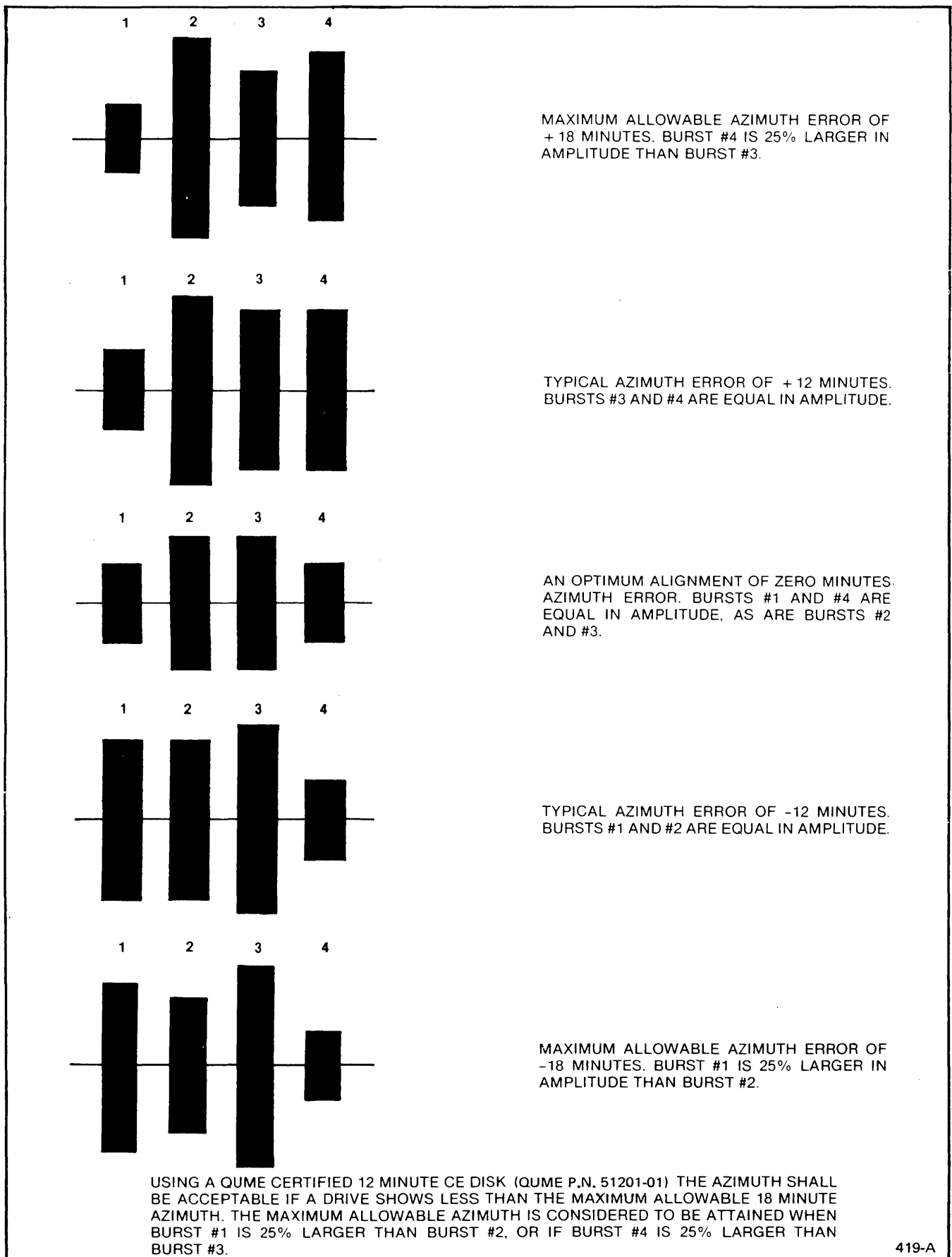

Figure 31, Azimuth Check

REMOVAL AND REPLACEMENT PROCEDURES

For the procedures outlined here, top and bottom of the disk drive must be freely accessible. Power is to be disconnected from the drive unless specifically instructed otherwise.

Refer to the Illustrated Parts Lists section for location and identification of subassemblies and parts.

CAUTION

The R/W head surfaces must not be permitted to contact each other. Whenever performing any work on the disk drive with the disk removed, a clean piece of paper is to be inserted in place of the disk between the R/W heads. Be sure that the paper remains between the heads in the head carriage assembly throughout a maintenance procedure.

PROTECTING THE R/W HEAD SURFACES

1. Manually slide the head carriage assembly all the way towards the rear of the drive (track 00 position).
2. Cut a strip of clean paper (approximately 1x4 inches) and fold it end-to-end to half length.
3. Carefully insert the paper, fold first, between the heads into the head carriage assembly (paper doubled over as described tends to stay in place more securely than a single straight strip of paper when the unit needs to be set on its side, thus providing more reliable R/W head protection).
4. Load the R/W heads against the paper by turning the Handle on the front bezel one quarter turn counterclockwise (CCW).

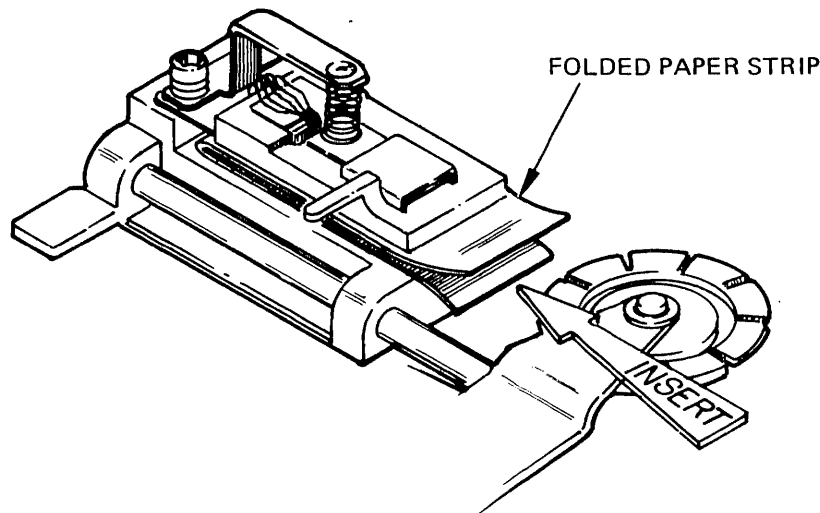

746-A-01

Figure 32, Protecting the R/W Head Surfaces

MAINTENANCE

DRIVE BELT AND SPINDLE DRIVE MOTOR

Removal

1. While turning the spindle pulley (with the black-and-white strobe decal) on the underside of the drive by hand to avoid stretching the drive belt, slide the belt off the spindle pulley.

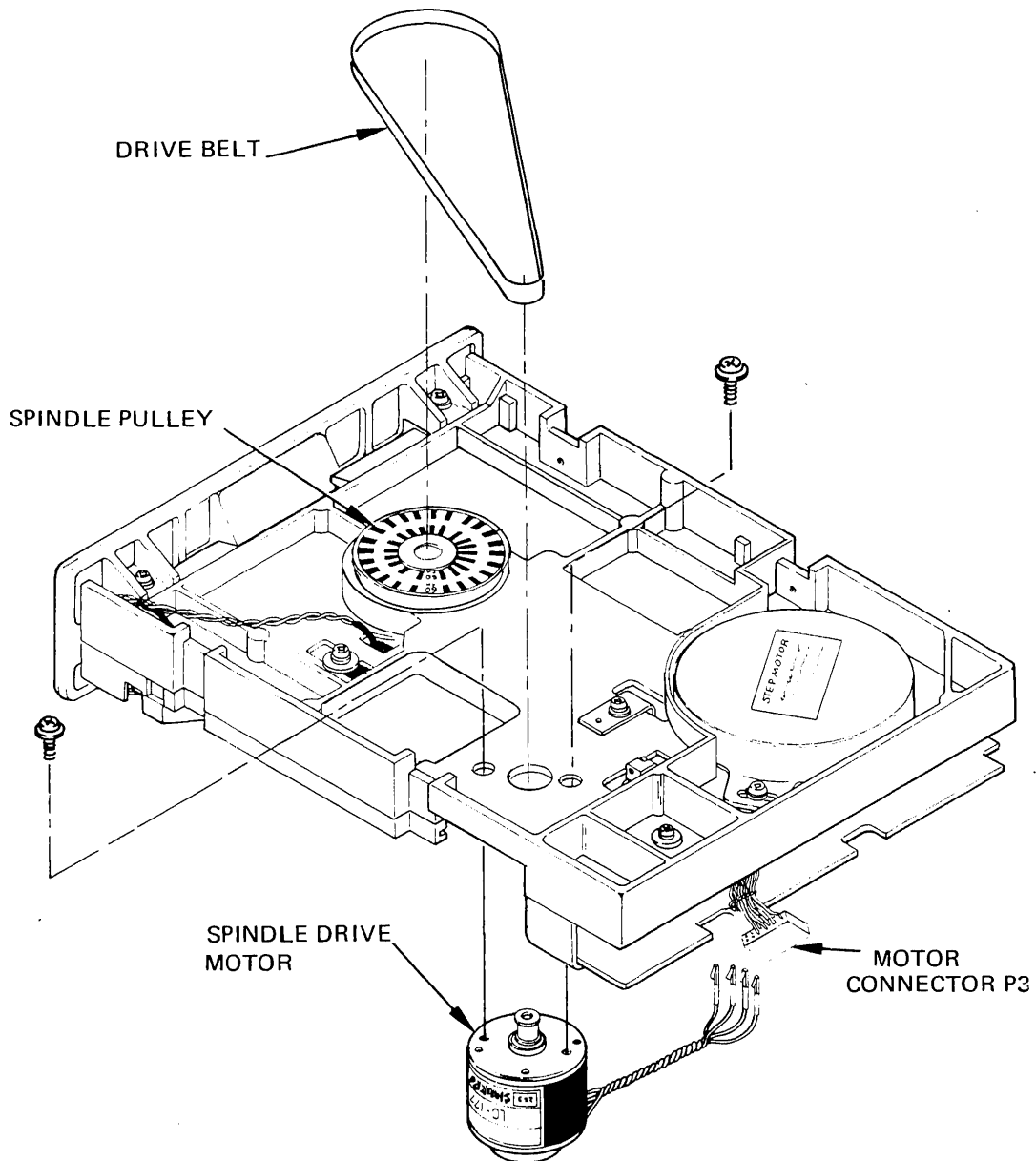

Figure 33, Spindle Drive Motor Removal

2. Note down the spindle drive motor and the tachometer wire colors and their terminal identification (A-1,2; B-1,2) at motor connector P3.

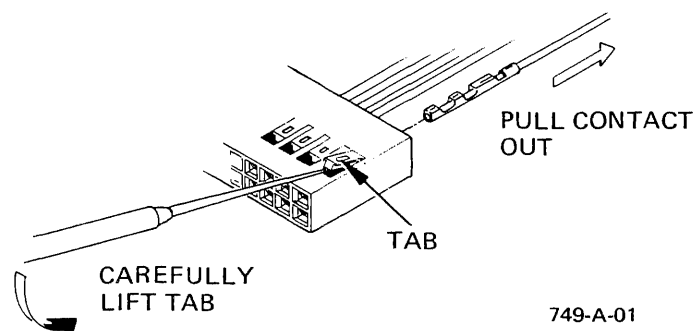

Figure 34, Releasing Contacts from Connector Body

3. With a pin or other suitably pointed instrument, gently lift on the connector P3 body the black locking tab of one of the motor wires and pull the wire and crimp-on contact out the back of the connector body.

Repeat this procedure for the remaining three wire contacts, being careful not to lift the locking tabs more than necessary to release the contacts.

4. Mark on the main frame casting the location of the two screws that mount the spindle drive motor to the casting by circling the screw heads as close as possible (use sharp pointed pencil or scribe) so that the replacement motor can be mounted in the same pre-aligned position.
5. Remove the two M3x0.5 screws that mount the spindle drive motor to the casting and lift the motor out, pulling its wires from under the PC Board.

Replacement

1. Follow the removal procedures in reverse order to install motor and drive belt. Mount the motor precisely in the original location by centering its mounting screws within the circular marks on the casting.

Be careful to return the motor wires to their proper contact locations in the body of connector P3.

2. Perform a Spindle Drive Belt Tension Check as outlined under Checks and Alignments.

PRINTED CIRCUIT BOARD (PCB)

Removal

1. Detach the following connectors from the PCB (refer to the Connector, Jumper and Test Point Locations illustration):

I/O Signal Connector	J1/P1;
Power Connector	J2/P2;
Motor Connector	J3/P3;
Head Connector	J4/P4;
Transducer Connector	J5/P5.

2. From the underside of the drive casting, near the rear corner next to the spindle drive motor, remove the M3x0.5 screw that mounts the C-shaped heatsink of motor drive transistor Q12 against the main frame casting.
3. From the topside of the drive, in the PCB's right corner, remove the M3x0.5 screw that mounts the PCB against the main frame casting.
4. Lift the PCB from the disk drive, back end first.

Replacement

1. Lay the PCB in position on the drive, making sure the red In Use LED is properly inserted into the front bezel hole and that the PCB front edge rests in the slots in the front bezel.
2. Install the two M3x0.5 PCB mounting screws (see steps 2 & 3, Removal); the screw with the larger washer below the casting. Be sure to line up the PCB's right side edge flush with the right media guide and the casting side before tightening the screws.
3. Re-attach the PCB connectors (see step 1, Removal).

FRONT BEZEL ASSEMBLY

Removal

1. Insert a strip of paper between the R/W heads as instructed under Protecting the R/W Head Surfaces.
2. Turn the Handle on the front of the drive one quarter turn CCW to load the heads against the protective paper strip and to lower the Carrier Assembly into operating position.

CAUTION

The R/W head surfaces must not be permitted to contact each other; be sure the protective paper strip is present as instructed.

3. Use a (approx. 4in.) length of not too stiff wire (e.g. 21 gauge bus wire) to tie the Carrier Assembly down in its operating position as follows:
 - below the carrier arm, locate the two openings in the main frame casting through which the index sensor is mounted;
 - from the top of the drive (carrier side) loop the tie wire down through one hole and back up through the other hole in the casting;
 - bend the wire down, snugly but not tight, against the top surface of the carrier arm and twist the wire ends together;
 - turn the Handle on the drive's front CW as if unloading the R/W heads and observe that the Carrier Assembly remains in its DOWN position (it may rise slightly, but not enough to touch the lifter arm on the Head Carriage Assembly).

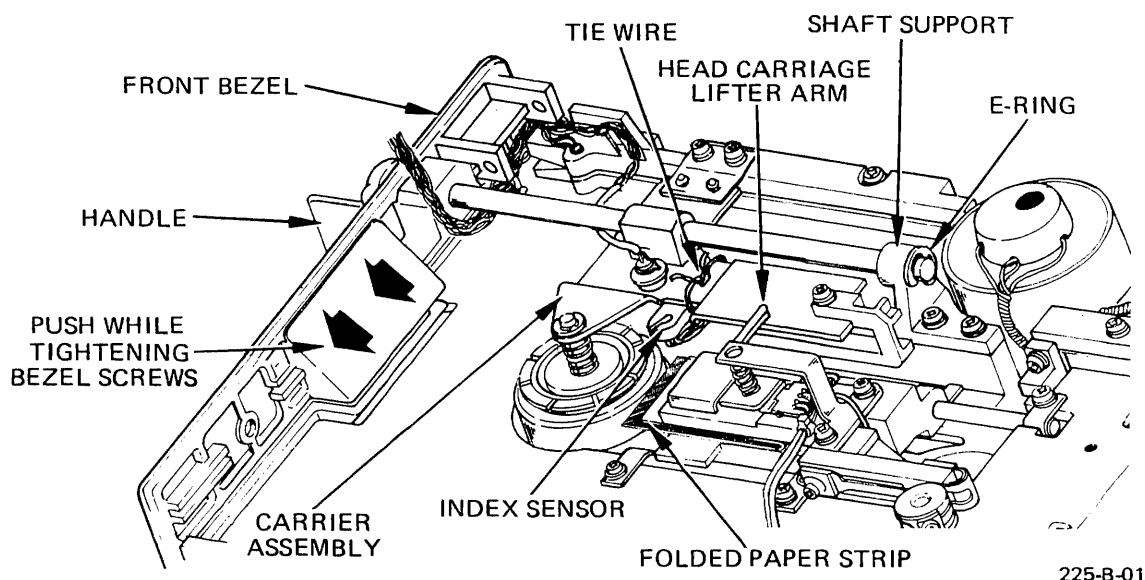

225-B-01

Figure 35, Front Bezel & Handle Assembly Removal

MAINTENANCE

4. Remove the retaining E-ring from the end of the handle shaft.
5. From the underside of the drive, remove the two M3x0.5 screws that mount the front bezel to the main frame casting.
6. Pull the Front Bezel Assembly (with Handle and shaft) forward and away from the main frame casting.

CAUTION

Damage to the Head Carriage Assembly will result if the Carrier Assembly is insufficiently tied down and is permitted to lift the R/W heads apart beyond their normal range of movement.

Replacement

1. When pushing the Front Bezel Assembly onto the drive from the front, be sure that:
 - the handle shaft end passes smoothly through the shaft support;
 - index lamp and transducer connector (P5) wires pass right **BELOW** the handle shaft and are almost touching the shaft's underside so that they will reliably clear a diskette upon its insertion or removal;
 - the wires leading to the underside of the main frame casting in the left front corner **are not being pinched** by the front bezel;
 - the In Use LED is properly inserted into the hole in the front bezel and that the PCB front edge rests in the slots in the front bezel.
2. Complete front bezel installation by following the removal procedure in reverse order. Be sure to hold the front bezel pushed fully towards the right of the drive (direction of arrow on the Front Bezel and Handle Ass'y Removal illustration) while tightening the two bezel mounting screws. Tighten the screws just enough to fully compress their lock washers; over-tightening will cause the plastic tabs of the front bezel to crack.

HANDLE ASSEMBLY

Removal

1. Follow steps 1 through 4 of the Front Bezel Assembly Removal instructions.
2. Turn the Handle on the front of the drive one quarter turn CW into unloading position.
3. From the left side of the drive, insert a medium size std. flat blade screwdriver (it is advisable to use demagnetized tools only) and remove the M3-14 flathead screw from the eccentric on the handle shaft; note orientation of the eccentric for proper placement when reassembling.
4. While pulling the handle shaft out through the front of the bezel, slide the eccentric from the shaft.

Replacement

1. Follow the removal procedures in reverse order. Be sure to properly orient the eccentric on the shaft so that the Carrier Assembly will be UP when the Handle is in horizontal, and DOWN when the Handle is in vertical position.
2. Push the Handle all the way against the front bezel.
3. Loosen the two shaft support mounting screws and slide the shaft support towards the rear of the drive to eliminate any excess play between shaft support and E-ring, but not enough to cause binding.

Tighten screws.

4. When installation of the Handle Assembly is completed, make sure that the index lamp wires and the transducer connector (P5) wire harness pass right BELOW the handle shaft and are almost touching the shaft's underside so that they will reliably clear a diskette upon its insertion or removal.

MAINTENANCE

HANDLE SHAFT SUPPORT

Removal

1. Follow steps 1 through 3 of the Front Bezel Ass'y. Removal instructions.
2. Remove the retaining E-ring from the end of the handle shaft.
3. Remove the two M3x0.5 screws that mount the handle shaft support to the main frame casting.
4. Pull Handle and shaft forward and away from the front bezel just enough so that the shaft end clears the shaft support.
5. Lift the shaft support out of the drive.

Replacement

1. Place the two M3x0.5 mounting screws into the long holes in the handle shaft support. While holding the shaft support above its place on the main frame casting, start both screws in their threads and tighten them just enough to still permit the support to slide about.
2. While pushing Handle and shaft up against the front bezel, insert the shaft end through the bore in the shaft support; continue until the Handle is all the way against the front bezel.
3. Install the retaining E-ring into the groove at the end of the shaft.
4. Slide the shaft support towards the rear of the drive to eliminate any excess play between shaft support and E-ring.
5. Remove the tie-down wire from around the carrier arm.

CARRIER ASSEMBLY

Removal

1. Remove the Front Bezel Assembly as outlined.
2. Remove the two M3x0.5 screws that mount the carrier assembly by its bronze spring to the left media guide.

Release the tie-down wire; carefully lift the Carrier Assembly from the hub and slide it out of the drive. While removing the Carrier Assembly from the drive, be careful not to raise the head carriage lifter arm beyond its normal range of travel, or damage to the head carriage may result.

Be sure not to lose the two cupped shim washers which may be present between the media guide and the casting.

3. Cut the black and the white wires leading to the index lamp at the location indicated in the Carrier Assembly Removal illustration; stagger the cut so that the wires end approximately 0.25 inch from each other (this will prevent an unnecessarily thick junction when re-joining the wires).
4. Lift the Carrier Assembly out of the drive.

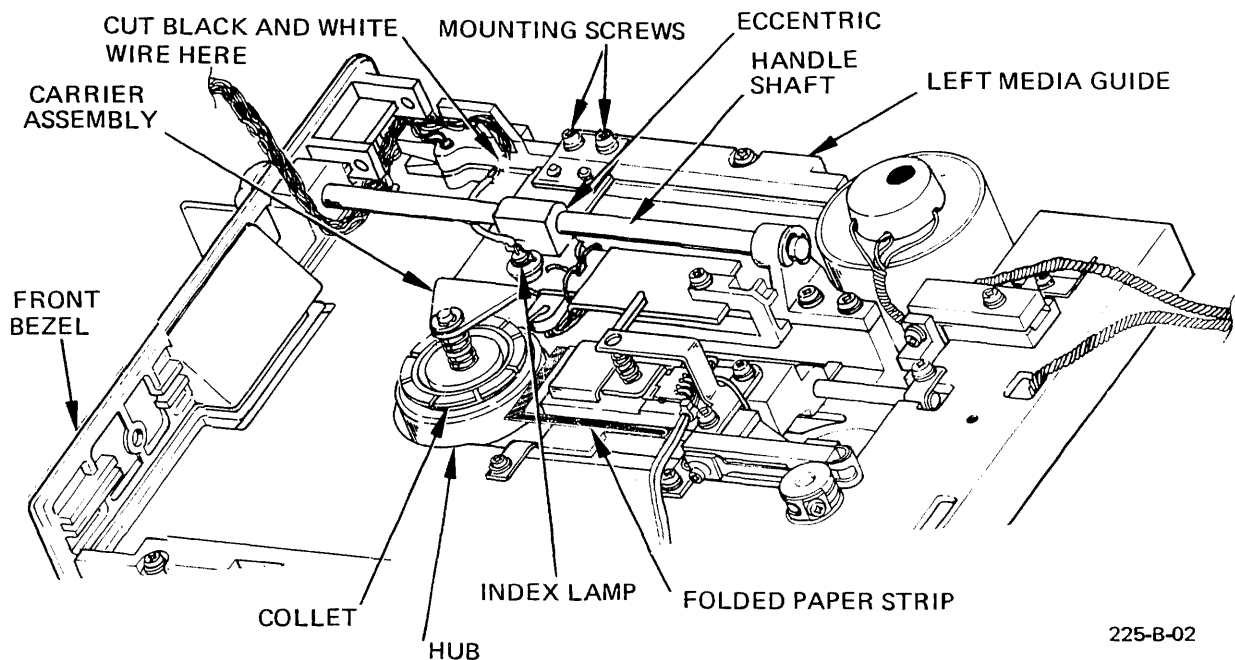

Figure 36, Carrier Assembly Removal

Replacement

1. Strip back approximately 0.25 inches of insulation on the white and the black wire ends from the transducer connector harness.

MAINTENANCE

2. On the replacement Carrier Assembly, strip back approximately 0.25 inches of insulation from the white and the black wires at the appropriate distance from the index lamp.
3. Slide small lengths of shrink tubing of appropriate size onto the wires; join and solder the wires together: white to white, and black to black; heat set the shrink tubing over the solder joints.

CAUTION

Direct the heat used to set the shrink tubing away from the interior of the disk drive.

4. Set the Carrier Assembly in place in the drive and manually seat the carrier collet in the spindle hub.

Loosely install the two M3x0.5 screws that mount the Carrier Assembly by its bronze spring to the left media guide, but do not tighten at this time. Only if shim washers were present under the media guide, place them -concave side down- over the tapped holes in the casting, before re-installing a Carrier Assembly.
5. Reinstall the Front Bezel Assembly as outlined under Front Bezel Assembly Replacement.
6. With the front bezel, Handle, handle shaft and eccentric in place, turn the Handle to vertical ("load") position; verify that the carrier collet is seated properly in the spindle hub.
7. Evenly, and in alternating succession, tighten the two carrier mounting screws, then loosen both screws by approximately 0.3 turn (just enough to permit lateral adjustment of the carrier).
8. Repeatedly turn the Handle to load and unload the carrier collet. Observe how the collet seats into the spindle hub and, by pushing the carrier to the appropriate position, eliminate any binding so that the collet seats itself smoothly into the hub.
9. Tighten the two mountingscrews and verify that the collet loads smoothly into the hub.
10. Make sure that the index lamp wires are up and out of the way and almost touching the handle shaft so that they cannot interfere with a diskette.
11. Insert a new and unused R/W diskette into the drive and load the carrier while very closely observing that the collet smoothly centers the diskette and seats itself without any binding.
12. Remove the diskette and examine its collet access hole on the label side (side 1). If any slide marks are found, or if binding was observed, the carrier alignment needs to be improved.

RIGHT MEDIA GUIDE

Removal

1. Remove the Printed Circuit Board as outlined.
2. Carefully note the routing of the R/W head cables leading to connector (P4) and mark on them (e.g. with a ball point pen) their position in the right media guide retaining slot. Pull the cables from the guide's slot.
3. Remove the two M3x0.5 screws that mount the right media guide to the main frame casting and lift the media guide off.
Be sure not to lose the two cupped shim washers which may be present between the media guide and the casting.

Replacement

1. Only if shim washers were present between casting and media guide, place them -concave side down- over the tapped casting holes when installing a replacement guide.
2. Follow the removal procedure in reverse order. Return both R/W head connector cables exactly to their original position in the media guide retaining slot and under the cable clamp on the casting so they will not restrict full range head carriage movement.
3. Perform Media Guide Rails Alignment as outlined in the Checks and Alignments section.

LEFT MEDIA GUIDE

Removal

1. Remove the Front Bezel Assembly as outlined.
2. Remove the two M3x0.5 screws that mount the Carrier Assembly by its bronze spring to the left media guide. Release the tie-down wire; carefully lift the Carrier Assembly out of the hub and slide it out of the drive. While removing the Carrier Assembly from the drive, be careful not to lift the head carriage lifter arm beyond its normal range of travel or damage to the head carriage may result.

Leave the wires to the index lamp connected and fold the Carrier Assembly out of the way.

3. Remove the two remaining M3x0.5 screws that mount the Left Media Guide Assembly to the main frame casting. Be sure not to lose the cupped shim washers that may be present between the media guide and the casting.
4. Cut the yellow and the black wires near the write protect lamp as indicated in the Left Media Guide Removal illustration. Stagger the cut so that the wires end approximately 0.25 inch from each other (this will prevent an unnecessarily thick junction when re-joining the wires).

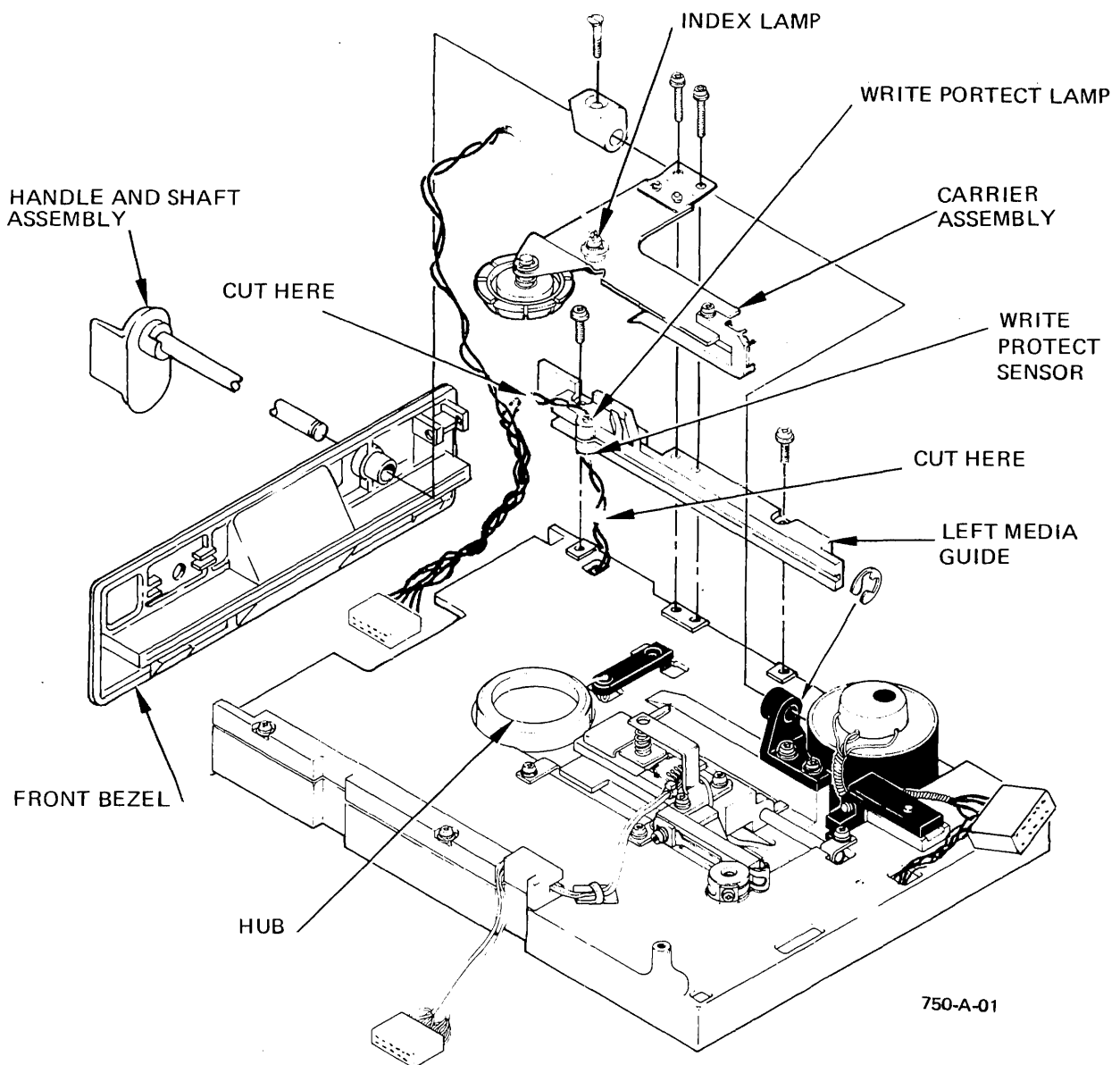

Figure 37, Left Media Guide Removal

5. Cut the orange and the black wires near the write protect sensor (see the Left Media Guide Removal illustration), staggering the cut as above.
6. Remove the Left Media Guide Assembly from the drive.

Replacement

1. Strip back approximately 0.25 inches of insulation on the yellow, the orange, and the two black wire ends from the transducer connector harness.
2. At the appropriate distances, strip back approximately 0.25 inches of insulation from the yellow and the black wires to the write protect lamp and from the orange and the black wires to the write protect sensor on the replacement Left Media Guide Assembly.

3. Slide small lengths of shrink tubing of appropriate size onto the wires; join and solder the wires together: yellow to yellow, orange to orange, and black to black; heat set the shrink tubing over the solder joints.

CAUTION

Direct the heat used to set the shrink tubing away from the interior of the disk drive.

4. Set the Left Media Guide Assembly and the Carrier Assembly in place in the drive and manually seat the carrier collet in the spindle hub.

Loosely install all four M3x0.5 screws that mount the media guide and carrier to the main frame casting but do not tighten at this time. Only if shim washers were present under the media guide, place them -concave side down- over the tapped holes in the casting before re-installing the left media guide.
5. Perform Media Guide Rails Alignment as outlined in the Checks and Alignments section.
6. Reinstall the Front Bezel Assembly as outlined under Front Bezel Assembly Replacement.
7. With the front bezel, Handle, handle shaft and eccentric in place, turn the Handle to vertical ("load") position; verify that the carrier collet is seated properly in the spindle hub.
8. Evenly, and in alternating succession, tighten the two carrier mounting screws, then loosen both screws by approximately 0.3 turn (just enough to permit lateral adjustment of the carrier).
9. Repeatedly turn the Handle to load and unload the carrier collet. Observe how the collet seats into the spindle hub and, by pushing the carrier to the appropriate position, eliminate any binding so that the collet seats itself smoothly into the hub.
10. Tighten the two mounting screws and verify that the collet loads smoothly into the hub.
11. Make sure that the transducer connector (P 5) harness and index lamp wires are all the way up and almost touching the handle shaft so that they cannot interfere with inserting or removing a diskette.
12. Insert a new, unused R/W diskette into the drive and load the carrier while very closely observing that the collet smoothly centers the diskette and seats itself without any binding.
13. Remove the diskette and examine its collet access hole on the label side (side 1). If any slide marks are found, or if binding was observed, the carrier alignment needs to be improved.

INDEX SENSOR

The Index Sensor is mounted in the drive's main frame casting, while the Index Sensor Lamp is inserted into a plastic sleeve in the Carrier Subassembly.

Should replacement of the Index Sensor Lamp become necessary:

1. Remove the Carrier Assembly as outlined.
2. With a thin rod (approximately 0.125 in. diameter) push the lamp out of its plastic sleeve from the underside of the carrier subassembly arm.
3. Insert the replacement lamp from the top of the carrier subassembly into the plastic sleeve so that the lamp's flange rests against the sleeve.
4. Reinstall the Carrier Assembly as outlined.

Outlined below is the procedure for replacing the Index Sensor.

Removal

1. Cut the blue and the black wires leading to the Index Sensor on the underside of the drive in the place indicated on the Index Sensor Removal illustration; stagger the cut so that the wires end approximately 0.25 inch from each other (this will prevent an unnecessarily thick junction when re-joining the wires).
2. On the underside of the drive remove the M3x0.5 screw and the large washer that secure the Index Sensor to the main frame casting.
3. Turn and slide the Index Sensor out from under the Carrier Assembly.

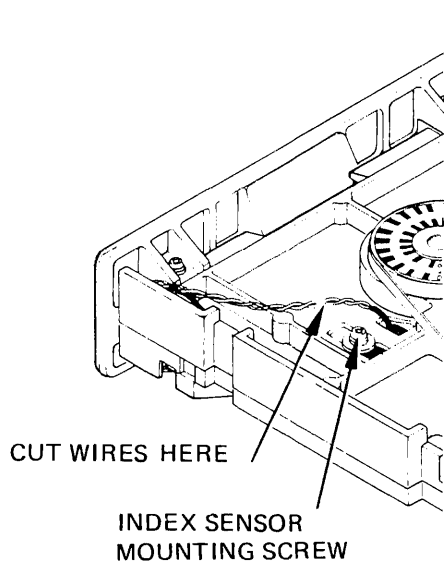

751-A-01

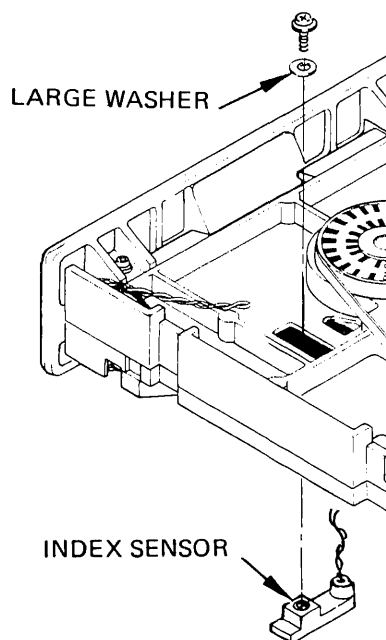

751-A-01

Figure 38, Index Sensor Removal

Replacement

1. Thread the connecting wires of the replacement sensor from the top of the drive through the hole in the casting next to the hub. Hold the sensor in place below the Carrier Assembly and mount it in place with the M3x0.5 screw and large washer from the underside of the drive.

Be careful not to exceed 3.5 lb. in. torque on the screw (use torque screwdriver).

2. Strip back approximately 0.25 inches of insulation on the blue and the black wire ends from the transducer connector harness.
3. On the replacement Index Sensor, strip back approximately 0.25 inches of insulation from the blue and the black wires at the appropriate distance from the index sensor.
4. Slide small lengths of shrink tubing of appropriate size onto the wires; join and solder the wires together: blue to blue, and black to black; heat set the shrink tubing over the solder joints.

CAUTION

Direct the heat used to set the shrink tubing away from the interior of the disk drive.

5. Perform Index Sensor Alignment as outlined under Checks and Alignments.

WRITE PROTECT SENSOR

Write protect sensor and write protect lamp are permanently mounted in the Left Media Guide Assembly. Should replacement of either, sensor or lamp, become necessary, the Left Media Guide Assembly is to be replaced as outlined.

TRACK 00 SENSOR

Removal

1. Remove the Printed Circuit Board (PCB) as outlined.
2. Note down the track 00 sensor and lamp wire colors and their terminal identification (A-3,4; B-3,4) at motor connector P3.
3. Release the respective wire contacts from the body of the motor connector P3 as outlined and illustrated under Drive Belt and Spindle Drive Motor Removal.
4. On the underside of the drive, remove the M3x0.5 screw and the large washer that secure the Track 00 Sensor Assembly to the main frame casting.
5. Lift the Track 00 Sensor Assembly out of the drive.

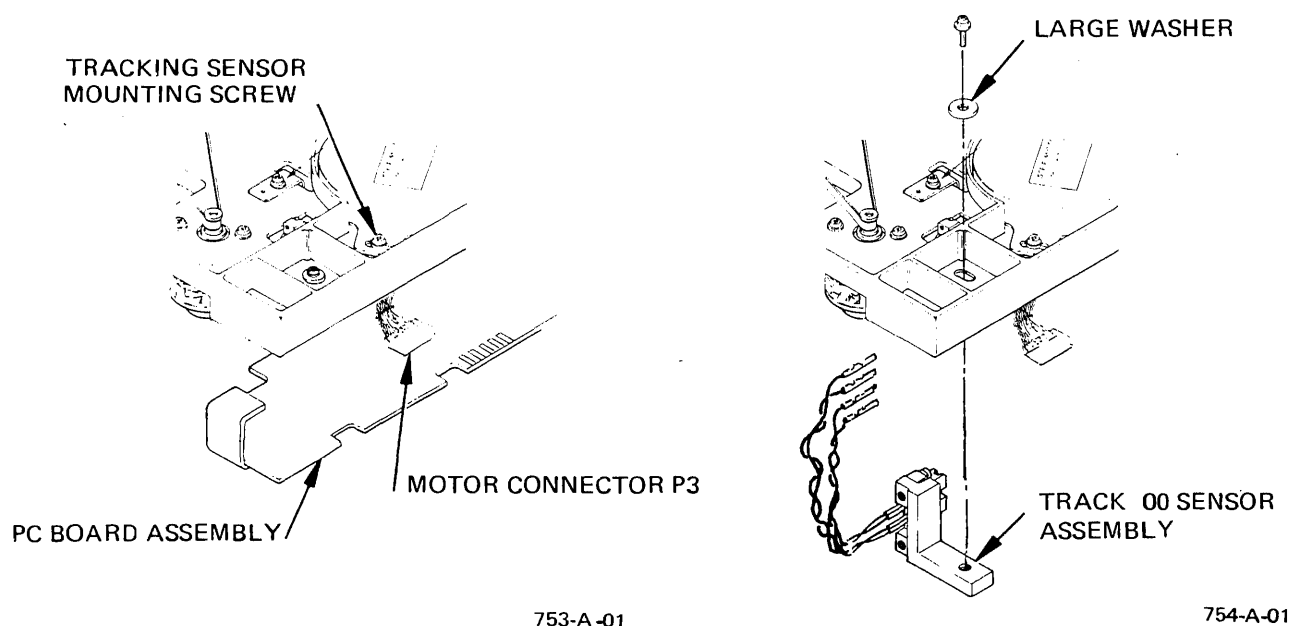

Figure 39, Track 00 Sensor Removal

Replacement

1. Follow the removal procedures in reverse order to install the Track 00 Sensor Assembly. Be careful to return the sensor and lamp wires to their proper contact locations in the body of connector P3.
2. Perform the Track 00 Sensor Alignment procedure outlined under Checks and Alignments.

STEEL BELT ASSEMBLY

The Steel Belt Assembly should be removed or replaced only by personnel experienced with this procedure, since belt or R/W head carriage are easily damaged, rendering the drive inoperative until replacement parts are obtained.

Removal

1. Remove the Printed Circuit Board as outlined.
2. Remove the M2.5x0.45 screw and "C"-shaped clamp plate that secure the Steel Belt Assembly to the stepper motor pulley.
3. Remove the two M2.5x0.45 screws that secure the Steel Belt Assembly ends to the R/W Head Carriage Assembly Base and lift the Steel Belt Assembly out of the drive. The end plates and the tensioning spring are spot welded onto the belt for reinforcement and are not removable.

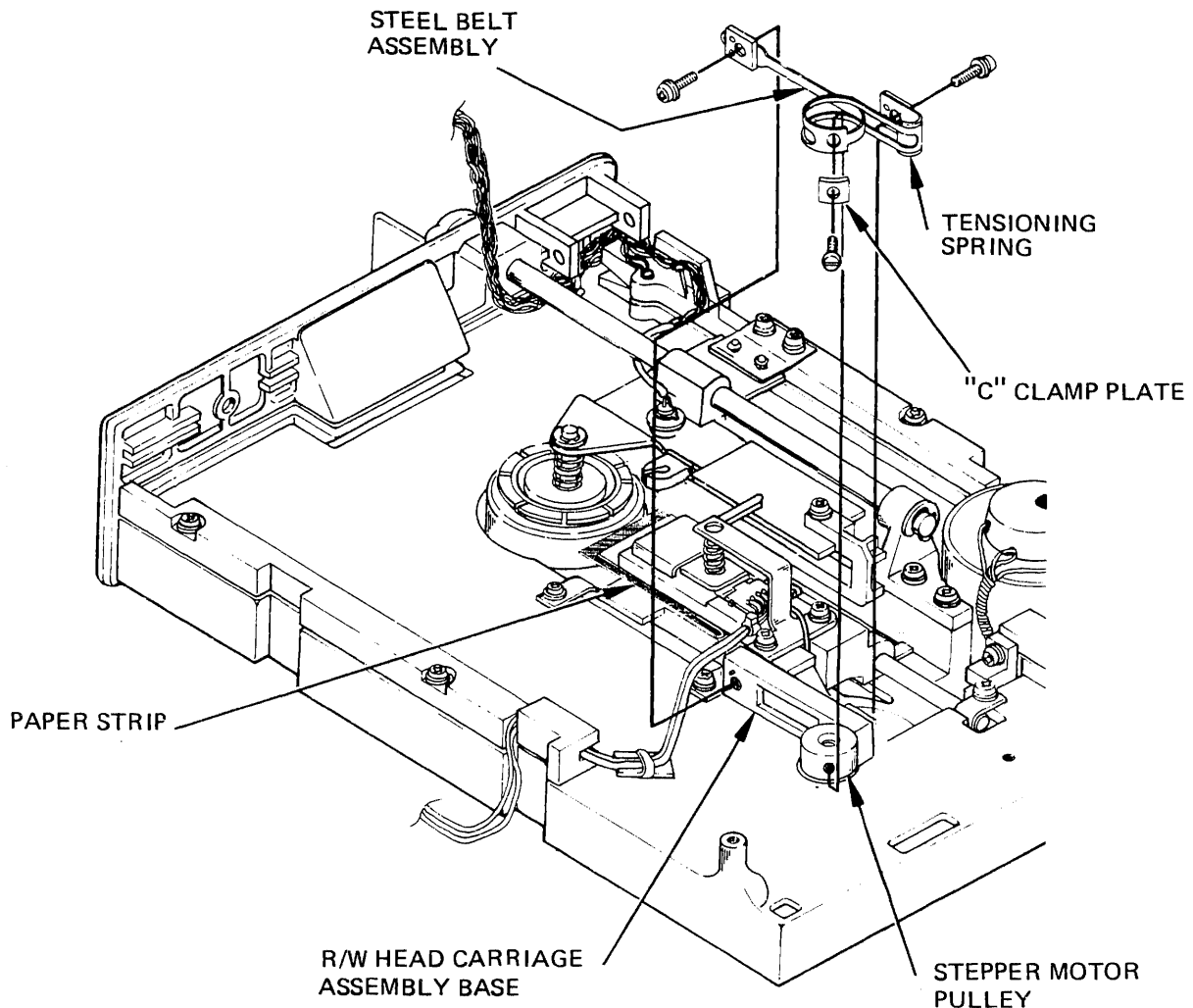

Figure 40, Steel Belt Removal

225-B-03

Replacement

CAUTION

Handle the steel belt carefully. The belt and its contact surfaces must be clean and free of any foreign matter. If the belt receives any kink or crease, it must be replaced, since this would prevent reliably accurate accessing of the tracks on a R/W diskette.

1. Loop the steel belt as shown in the Steel Belt Replacement illustration by passing end "A" with the single strand through the belt's split part.
2. Slide the loop over the stepper motor pulley as illustrated and place belt end "B" onto the R/W Head Carriage Assembly Base so that the two small dowels on the back of the carriage base engage in the two holes in the belt end plate.

Loosely secure belt end "B" in place by installing the M2.5x0.45 screw finger tight only.

3. Hook a thin spring hook into the small hole in the tip of the belt end "A" (pass the hook **below** the R/W head cables) and carefully pull the belt until the holes in the belt end plate can be engaged over the two small dowels on the front of the carriage base (let the carriage follow the direction of pull without restraining it until it stops at its natural end of travel near the spindle hub). Do not let the lower strand of the belt's split part slip off the rear of the stepper motor pulley; it is easily damaged if wedged between pulley and casting. The single belt strand should run on the pulley centered between the outer two strands.

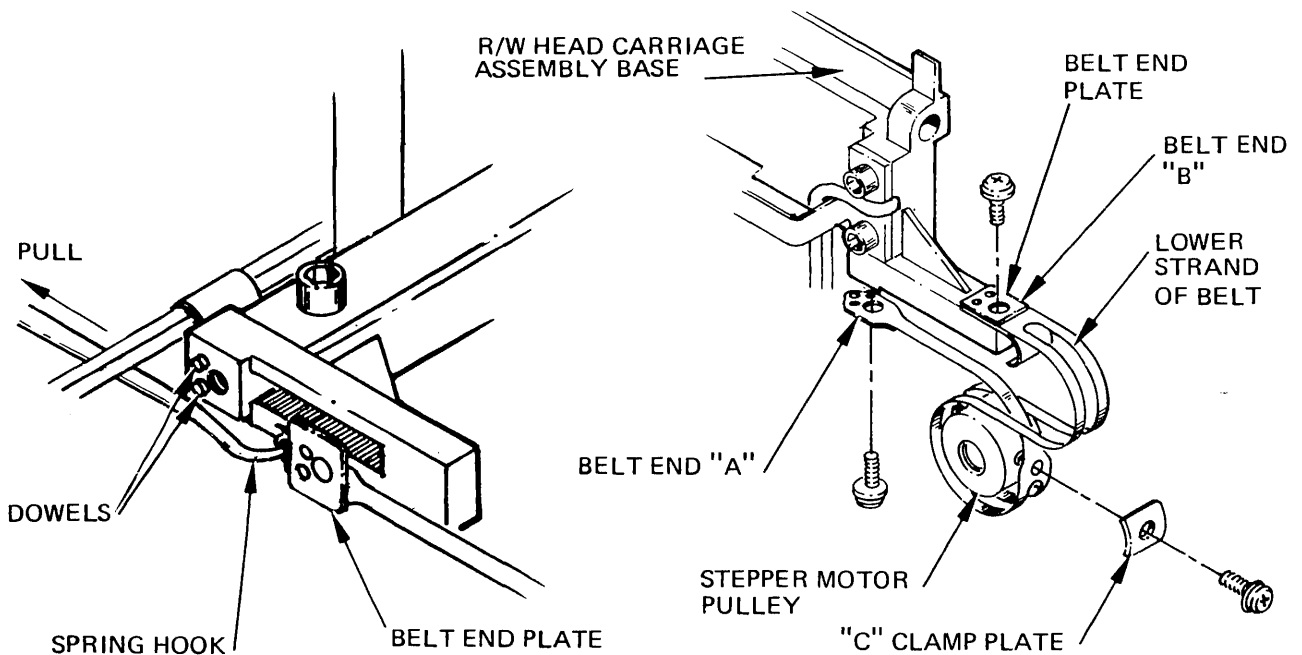

Figure 41, Steel Belt Replacement

4. Secure belt end "A" by installing the M2.5x0.45 screw finger tight only; remove the spring hook.
5. Manually slide the R/W Head Carriage Assembly several times back and forth over its full range of travel to equalize the tension in the belt and to let the belt position itself properly.

The belt strands should travel at even spacing and **straight** on the motor pulley surface. Carefully listen for any noise that may be evidence of the belt's strands rubbing against each other at the rear of the motor pulley and eliminate this by adjusting the belt's position on the pulley.

6. Place thumb and index finger exactly as shown in the Aligning Steel Belt Hole and Pulley Thread illustration. Slightly compress the tensioning spring at belt end "B" so that the belt tension is reduced **just enough** to permit rotating the stepper motor pulley by pressing and twisting a thumb on its top surface. Rotate the stepper motor pulley until its threaded hole and the hole in the belt line up.

CAUTION
Do not bend the belt tensioning spring.

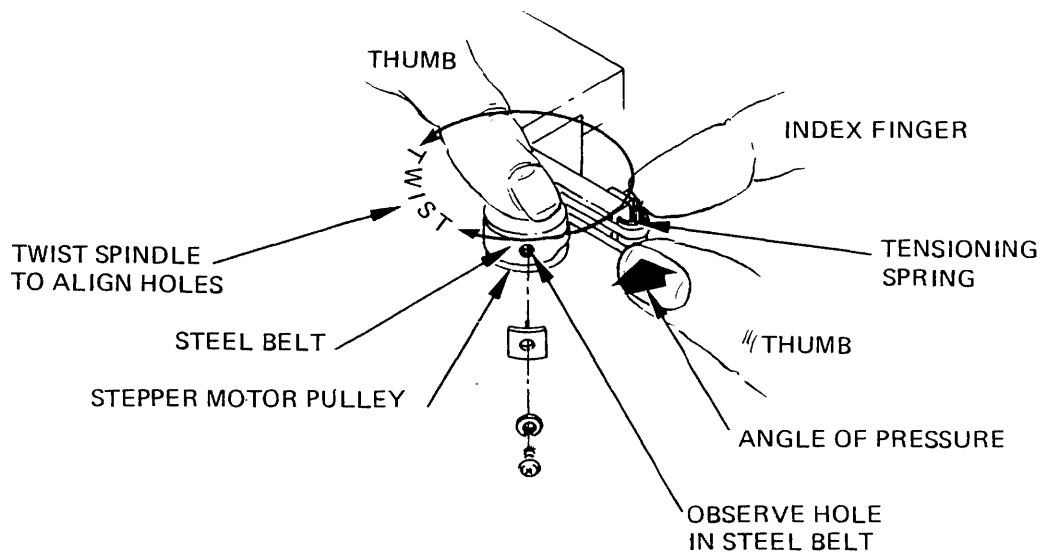

765-A-01

Figure 42, Aligning Steel Belt Hole and Pulley Thread

7. Loosely secure the belt on the stepper motor pulley with the "C"-shaped clamp plate and M2.5x0.45 screw; do not tighten the screw at this time.
8. Repeat step 5 above.
9. Tighten all three M2.5x0.45 belt mounting screws; hold the belt end plates in position to prevent twisting.
10. Repeat step 5 above. It may be necessary to loosen and re-tighten the screws if the belt beneath them has twisted during tightening.

11. Check for proper R/W Head Carriage Assembly travel:

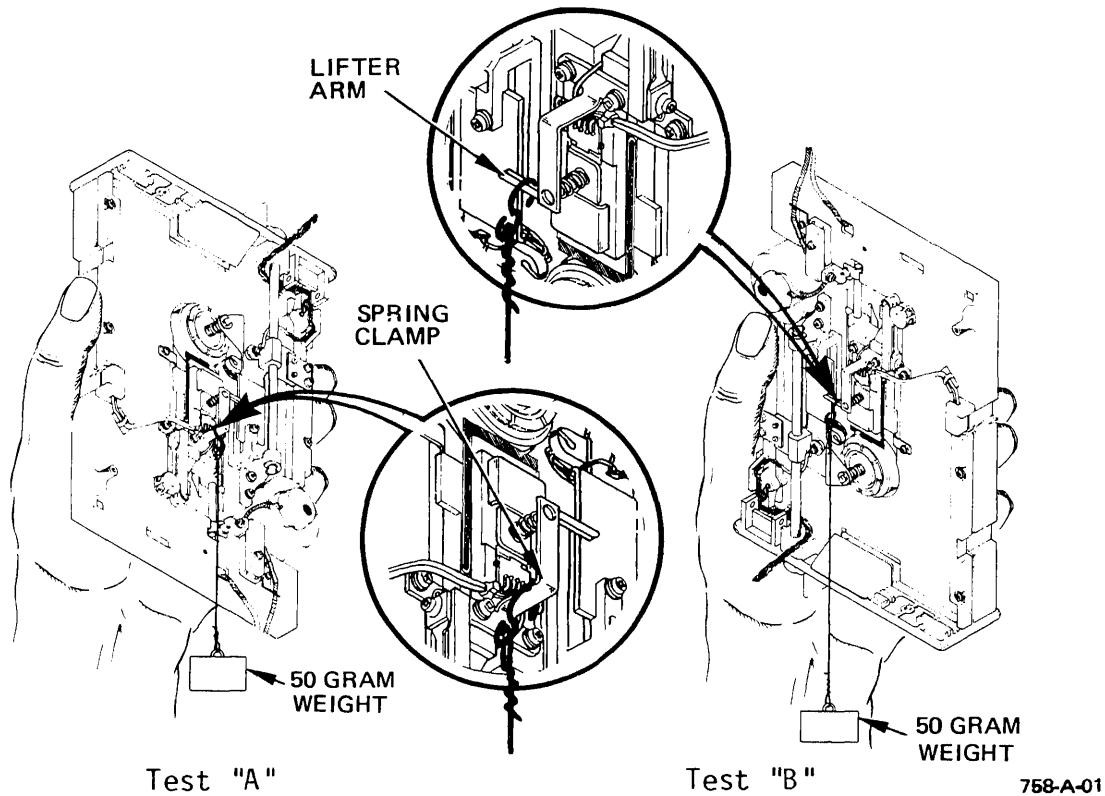

Figure 43, R/W Head Carriage Free Movement Test

- load the R/W heads against a protective paper strip as instructed under Protecting the R/W Head Surfaces.
- hold the drive by its main frame casting in vertical position, with the front bezel **up**.
- suspend a 50 gram (1.76 oz.) weight from the head assembly spring clamp as illustrated by "Test A";
- manually slide the R/W Head Carriage Assembly all the way up to the end of its travel range towards the spindle hub;
- release the carriage; the weight must pull the carriage down smoothly all the way to the other end of its travel range;
- repeat the process, holding the drive by its casting, front bezel **down**; hang the weight from the Head Carriage Lifter Arm as illustrated by "Test B"; manually slide the R/W Head Carriage Assembly all the way up (away from the spindle hub), then release it for the check.

If necessary, re-seat the belt.

11. Reinstall the Printed Circuit Board as outlined.
12. Perform R/W Head Radial Positioning Alignment as outlined.

STEPPER MOTOR

Removal

1. Remove the Steel Belt Assembly as outlined.

CAUTION

Handle the steel belt carefully. If the belt is damaged in any way, it must be replaced, since this would prevent reliably accurate accessing of the tracks on a R/W diskette

2. Note down the stepper motor wire colors and their terminal identification (A-5,6,7; B-5,6,7) at motor connector P3.
3. Release the respective leads from the body of the motor connector P3 as outlined and pictured under Drive Belt and Spindle Drive Motor Removal.
4. On the underside of the drive, remove the two M3x0.5 screws that mount the stepper motor to the main frame casting and lift the stepper motor out of the drive.

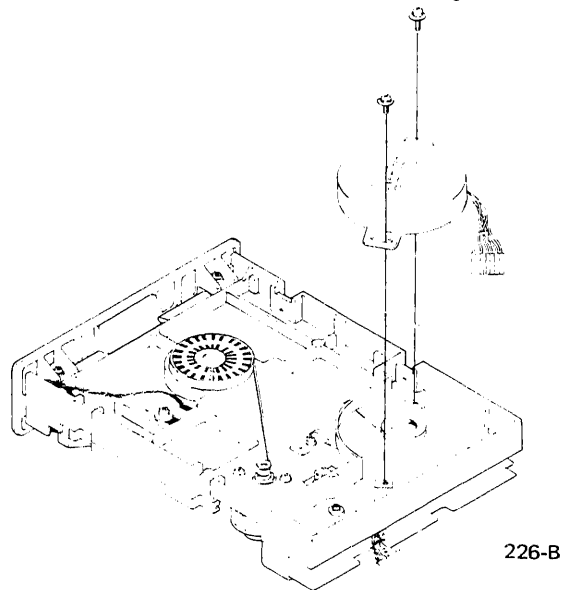

Figure 44, Stepper Motor Removal

Replacement

1. Follow the removal procedures in reverse order to install the stepper motor. Make sure that under motor or mounting flange no wires are pinched and (by repeated twisting) that the motor seats properly in the casting before tightening its mounting screws.

Be careful to return the motor connecting wires to their proper contact locations in the body of connector P3.

2. At the completion of reinstalling the steel belt, perform R/W Heads Radial Positioning Alignment as outlined under Checks and Alignments.

MAINTENANCE

R/W HEAD CARRIAGE ASSEMBLY

REMOVAL

1. Remove the PCB as outlined under Printed Circuit Board Removal.
2. Remove the Front Bezel Assembly exactly as outlined in order to avoid damage to the R/W Head Carriage.
3. Remove the Carrier Assembly as outlined, but do not cut the index lamp wires.
4. Remove the Steel Belt Assembly:
 - remove the M2.5x0.45 screw and "C"-shaped clamp that secure the Steel Belt Assembly to the stepper motor pulley;
 - remove the two M2.5x0.45 screws that secure the Steel Belt Assembly ends to the R/W Head Carriage Assembly Base and lift the Steel Belt Assembly out of the drive.

CAUTION

Handle the steel belt carefully. If the belt receives any kink or crease, it must be replaced, since this would prevent reliably accurate accessing of the tracks on a R/W diskette.

5. Pull both R/W head cables from the retaining slot in the right media guide and release them from the cable clamp on the casting, after carefully noting down and marking on them (e.g. with ball point pen) their routing from the carriage through the media guide.
6. Release the left (longer) carriage guide bar by removing the front and the rear M3x0.5 screws that hold both guide bar clamps in place.
7. Tilting up the left side of the R/W Head Carriage Assembly first, lift the entire R/W Head Carriage Assembly, with the left carriage guide bar in place, out of the drive.

Replacement

1. Make sure a protective paper strip is present between the R/W head surfaces as outlined under Protecting the R/W Head Surfaces.
2. Insert the left (longer) carriage guide bar through the two bearing holes in the left side of the R/W Head Carriage Assembly.
3. Place the R/W Head Carriage Assembly (with the left guide bar) into the drive by first engaging the "C"-shaped bearing on the carriage's right side over the right (short) guide bar on the main frame casting; then lowering its left side so that the left guide bar rests on the (front and back) recesses in the casting.

4. Install the guide bar clamps over both ends of the left carriage guide bar, using the two M3x0.5 screws.

Make sure that the clamps are exactly square with the guide bar and do not turn as their screws are tightened.

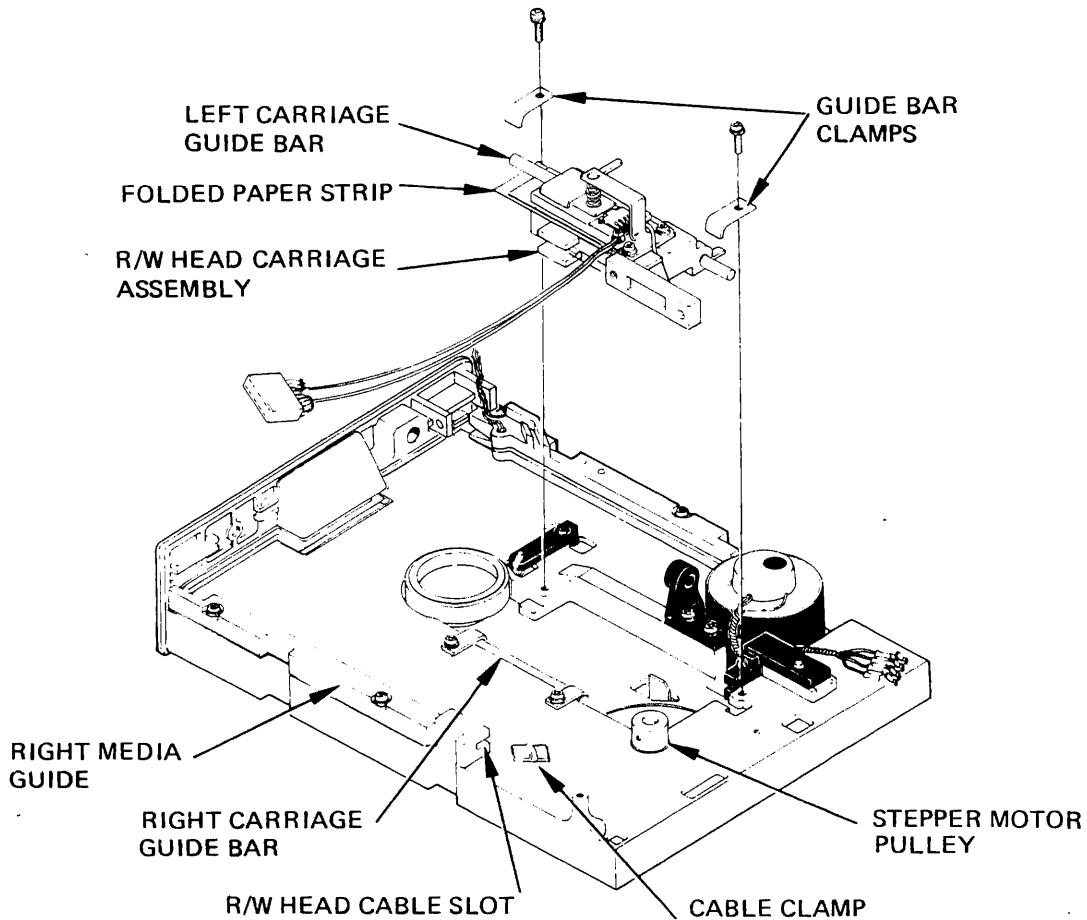

761-A-01

Figure 45, R/W Head Carriage Removal

5. Place the two R/W head cables back under the cable clamp on the casting and into the retaining slot in the right media guide exactly as was their original placement **so that they will not restrict free full range head carriage movement.**
6. Check that the R/W Head Carriage Assembly glides freely on its guide bars and that the guide bar clamps do not interfere.
7. Install the steel belt as outlined under Steel Belt Assembly Replacement.
8. Reinstall the Carrier Assembly and the Front Bezel Assembly (except for reconnecting the index lamp wires) exactly as outlined under Carrier Assembly Replacement.
9. Reinstall the Printed Circuit Board as outlined.

TROUBLESHOOTING

GENERAL

This section contains troubleshooting information dealing with possible QumeTrak 142 functional errors, namely: Seek Error, Read Error, and Write Errors. Troubleshooting of these errors is presented in flowchart format.

DEFINITION OF QUMETRAK 142 FUNCTIONAL ERROR TERMS

SEEK ERROR - A condition in which the drive is unable to access a particular diskette side or track, or to confirm track 00 access to the controller.

READ ERROR - A condition in which the drive is unable to recover data previously written onto a diskette.

WRITE ERROR - A condition in which the drive is unable to write data onto a diskette.

TROUBLESHOOTING TECHNIQUE

For troubleshooting, the disk drive unit must be energized, with its PCB and drive mechanisms freely accessible.

Effective troubleshooting should always begin with some basic checks and a process of elimination:

1. Eliminate the possibility of the diskette being the cause of malfunction:

- verify that the malfunction at hand is not caused by a diskette incompatible with the overall system, see Proper Diskette Use in the Operation section;
- verify that the diskette is inserted into the drive facing the right way, i.e. with the label on the diskette facing the front bezel side with the Handle and the In Use LED, see Inserting Diskette in the Operation section;
- use another diskette known to have good data written on it; most diskette problems can be attributed to either "soft" or "hard" errors:

"Soft" disk errors are (sometimes temporary) recoverable reading errors. They are typically caused by contamination of the diskette surface picked up in careless use and handling. Repeated reading attempts may result in successfully retrieving the information on the diskette; subsequently, the file should be transferred to a new diskette and the old diskette discarded.

"Hard" errors are permanent (or non-recoverable) in nature. They are typically caused by particles in excess of head gap size, by microscopic voids or pits in the diskette surface, or by scratches and abrasions, all of which permanently damage the diskette and result in

TROUBLESHOOTING

error pulses or glitches in the recorded data. A soft error, when occurring during a write cycle, will cause a recorded hard error.

2. Verify that DC power and frame ground connections are reliable and that power levels supplied to the drive are as specified under Physical Interface in the Interface section and in the Installation Requirements table in the Installation section.
3. Next, perform a visual inspection; look for such things as faulty wiring, damaged or misaligned components, and the presence of any foreign matter, such as dust. Inspect for anything that can obviously alter performance of the drive.
4. The most efficient way to find out whether a malfunction is caused by a defective drive is to exchange a suspect unit with one known to be in good working order. If a compatible exchange QumeTrak 142 drive is available, its internal drive select (DS) jumper status needs to be verified as outlined under Addressing in the Interface section before it is connected to a system.
5. Once the drive unit is found to be functional, verify that the interface and controller programming are viable.

TROUBLESHOOTING FLOWCHARTS

To proceed through the following troubleshooting flowcharts, the following equipment is required:

- host system or disk drive controller;
- R/W diskette with data of known good integrity; CE diskette, Qume P.N. 51201-01 may also be helpful;
- multimeter, 20,000 Ohm/Volt, or better;
- oscilloscope, dual trace.

If it becomes necessary to replace subassemblies or to perform functional checks or adjustments within the QumeTrak 142, these actions should be taken as instructed under the pertaining headings in the Removal and Replacement Procedures and the Checks and Alignments, respectively, in this manual.

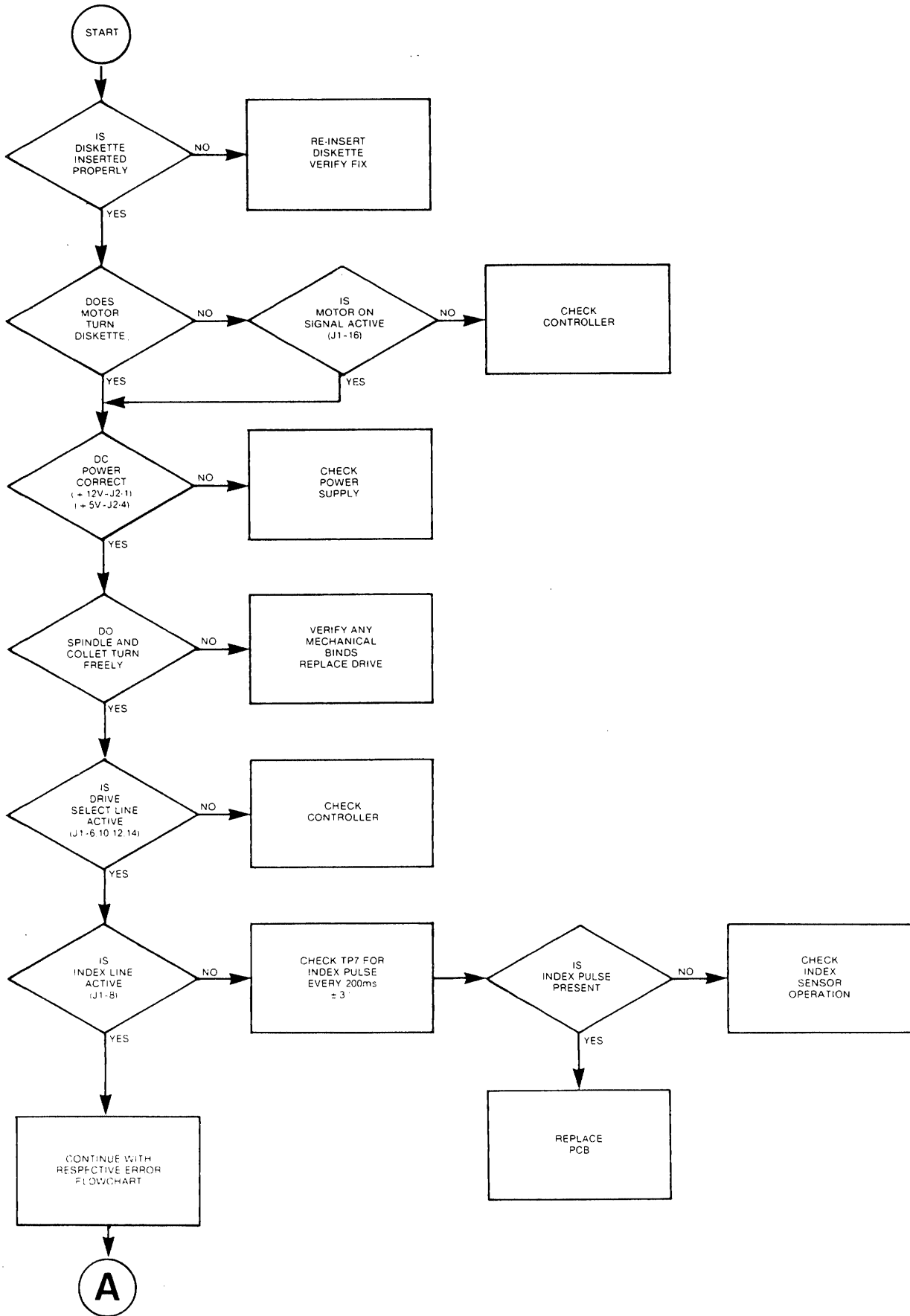
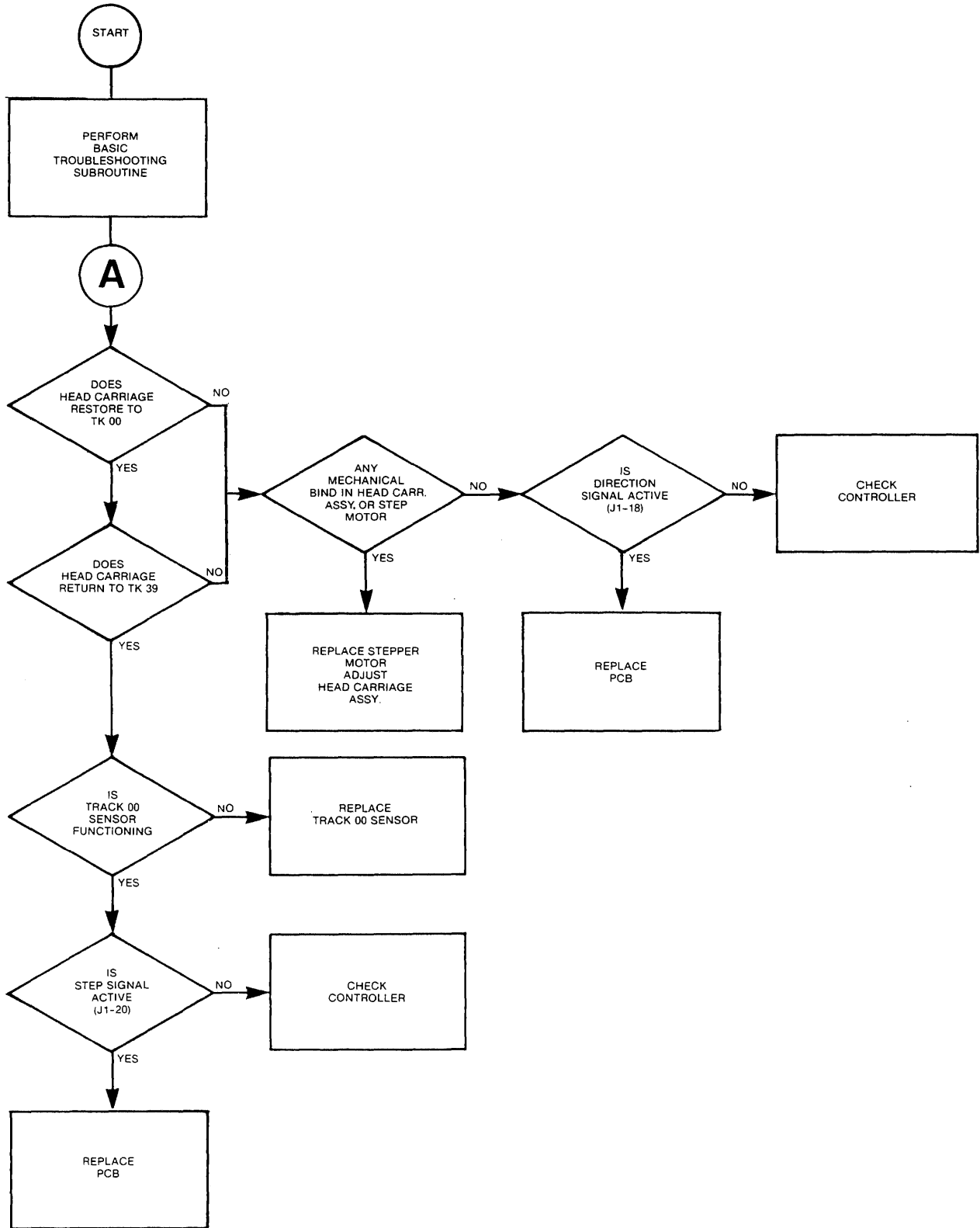
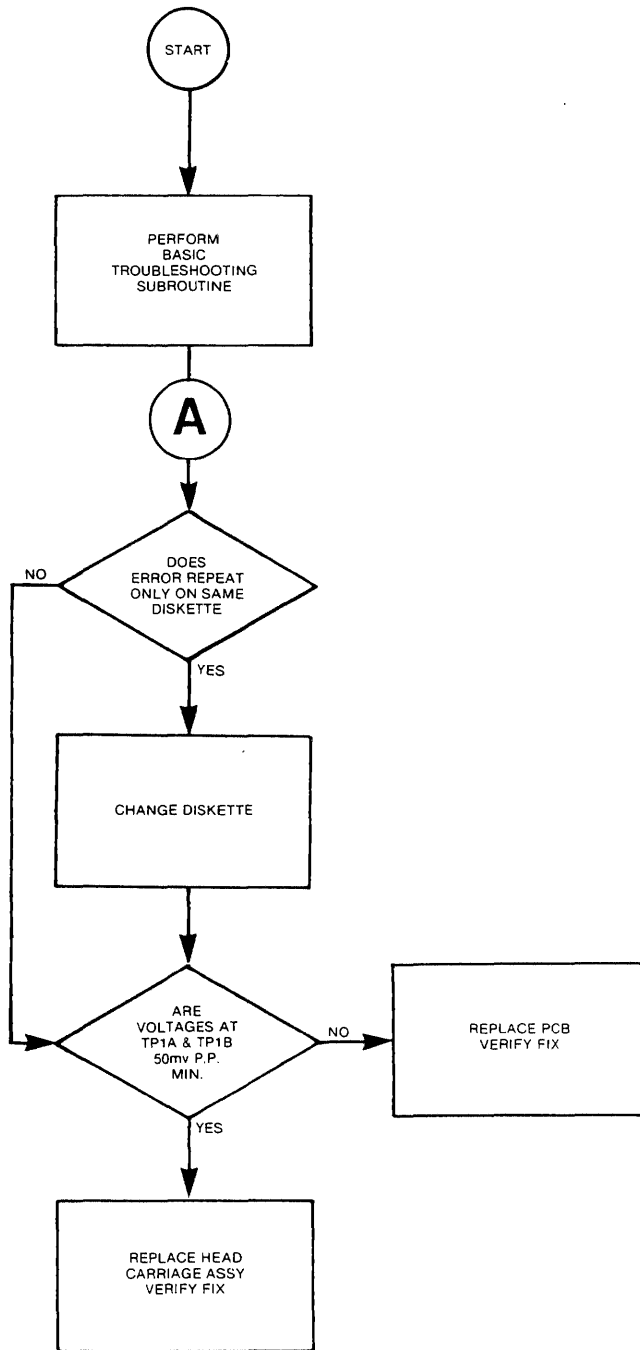

Figure 46, Basic Troubleshooting Subroutine Flowchart



101-B-01

Figure 47, Seek Error Troubleshooting Flowchart



011-B-01

Figure 48, Read Error Troubleshooting Flowchart

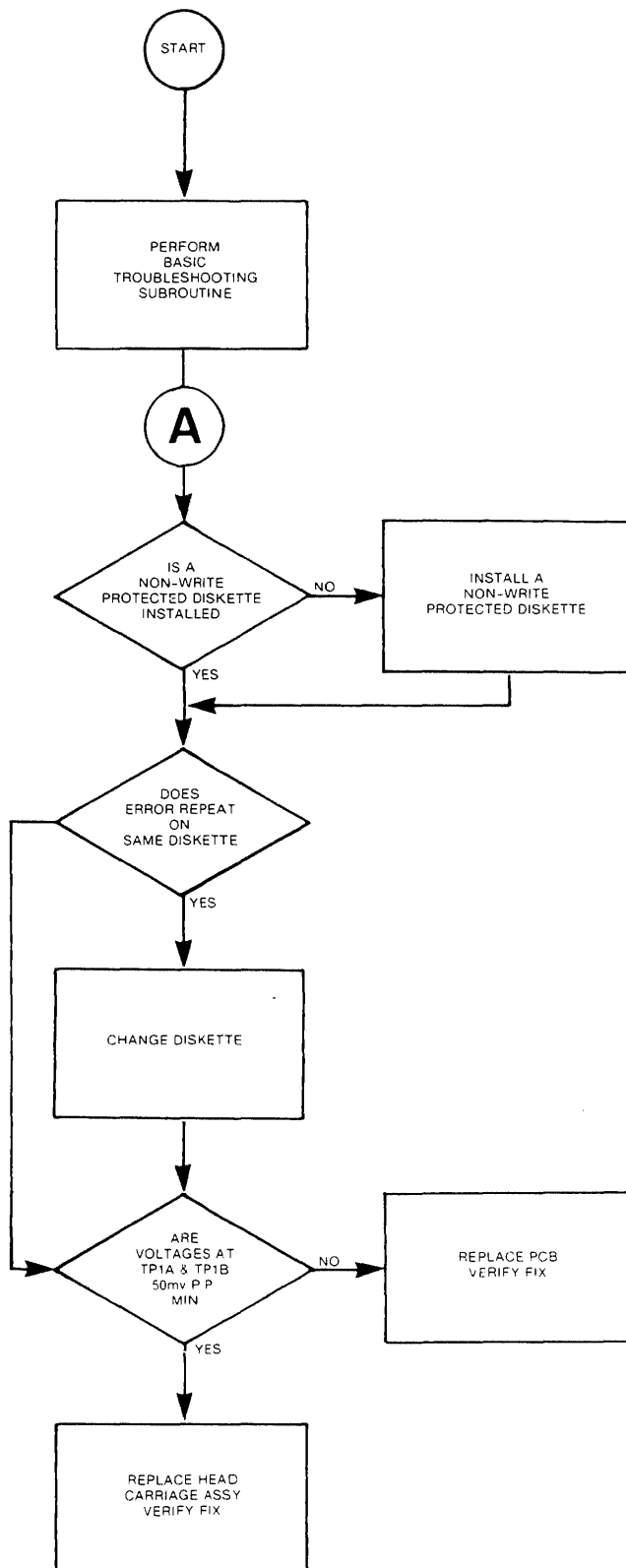

009-B-01

Figure 49, Write Error Troubleshooting Flowchart

RECOMMENDED SPARE PARTS

Listed in the following table are the recommended spare parts according to description, part number, and quantity for supporting the QumeTrak 142 flexible disk drive. Refer to the Illustrated Parts Lists for parts identification.

Table 10, Recommended Spare Parts

DESCRIPTION	QUME PN	NUMBER OF DISK DRIVES		
		1000	5000	10 000
NUMBER OF SPARE PARTS				
PRINTED CIRCUIT BOARD (PCB) ASSEMBLY	90688-03	20	100	200
HEAD CARRIAGE ASSEMBLY	53327-01	20	100	200
D.C. DRIVE MOTOR ASSEMBLY	53407-01	3	15	30
STEPPER MOTOR ASSEMBLY	53408-01	3	15	30
STEEL BELT ASSEMBLY	53040-01	3	15	30
SPINDLE DRIVE BELT	53360-01	3	15	30
COLLET CONE	53380-01	3	15	30
COLLET	53381-01	3	15	30
CONE SPRING	85645-81	3	15	30
COLLET SPRING	53388-01	3	15	30
E-RING	85128-25	3	15	30

ILLUSTRATED PARTS LISTS

The following pages contain illustrated assemblies and corresponding parts lists for the QumeTrak 142 Flexible Disk Drive. The illustrations provide an assembly guide and may be used for identification of missing or broken parts when repairing a disk drive. Some parts may be illustrated for clarity only. Parts not shown or listed are not available.

This section consists of the following illustrated parts lists:

- Final Assembly
- Carrier Assembly
- Media Guide Frame Assembly

FINAL ASSEMBLY

<u>Item</u>	<u>Part No.</u>	<u>Description</u>
1.	53373-01	Front Bezel Assembly
2.	53312-01	Carrier Assembly (Note 2)
3.	53327-01	Carriage Assembly
4.	53341-01	Sensor Assembly, Track 00
5.	90688-01	PCB Assembly
6.	53356-01	Index Sensor Assembly
7.	53040-01	Steel Belt Assembly
8.	53407-01	D.C. Motor Assembly
9.	53408-01	Stepper Motor Assembly
10.	53337-01	Clamp, Guide Bar
11.	53335-01	Guide Bar, Left
12.	53335-02	Guide Bar, Right
13.	53360-01	Spindle Belt
14.	53393-01	Stopper, Track 00
15.	-----	Media Guide Frame Assy (Note 3)
16.	53042-01	Belt Clamp
17.	53304-02	Shaft Support
18.	94298-14	Connector

Notes:

- (1) Parts not listed are not available separately. Order complete drive assembly, P.N. 53301-XX.
- (2) For illustrated parts breakdown, see next section.
- (3) Not available as an assembly. For illustrated parts breakdown, see Media Guide Frame Assembly section.

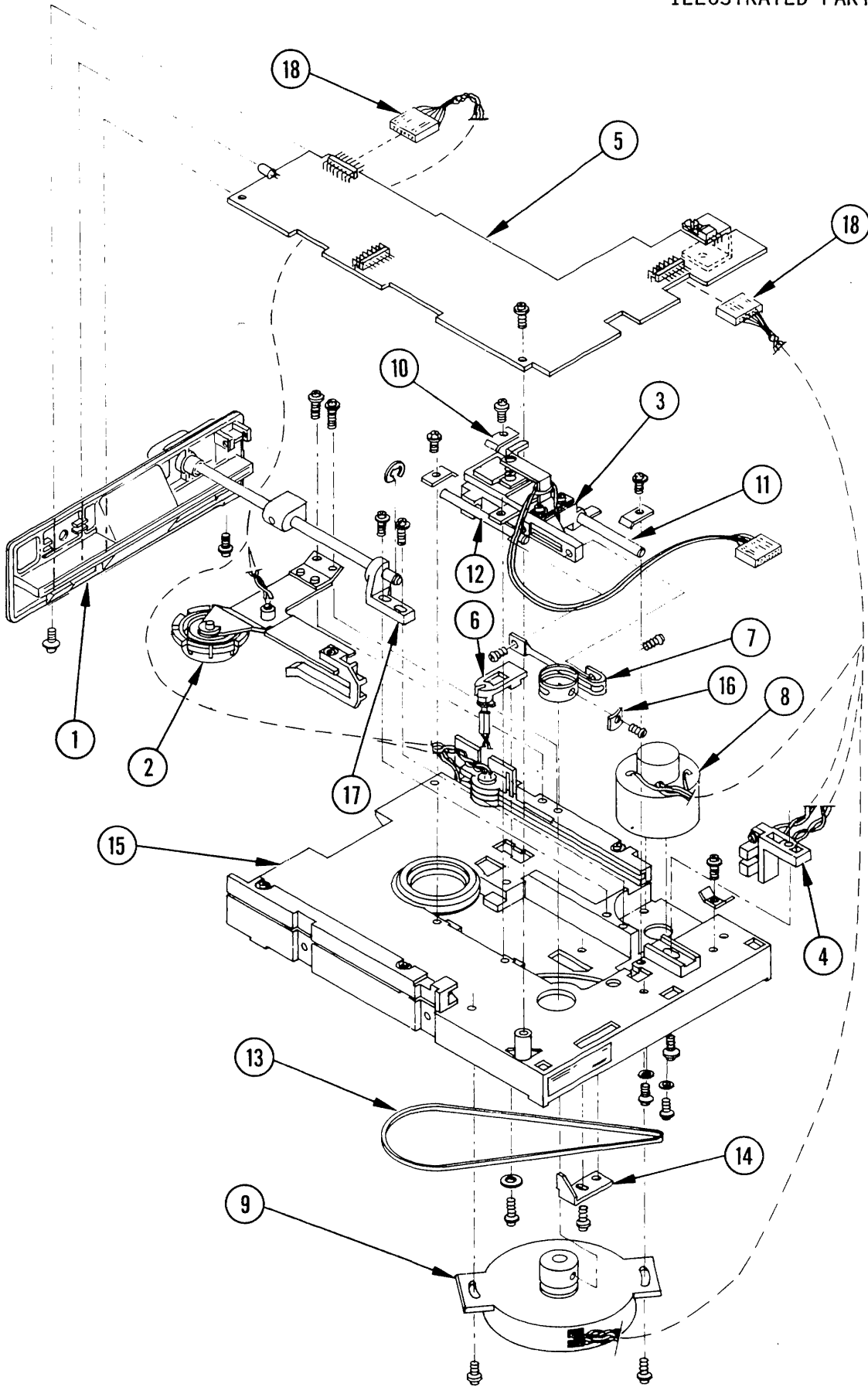

FINAL ASSEMBLY

203-B-04

CARRIER ASSEMBLY

<u>Item</u>	<u>Part No.</u>	<u>Description</u>
1.	85645-81	Cone Spring
2.	85144-08	Ball Bearing
3.	53380-01	Collet Cone
4.	53388-01	Collet Spring
5.	53381-01	Collet
6.	53322-01	Collet Shaft
7.	53313-01	Carrier Subassembly
8.	85128-25	E-Ring
9.	53325-01	Index Lamp Assembly

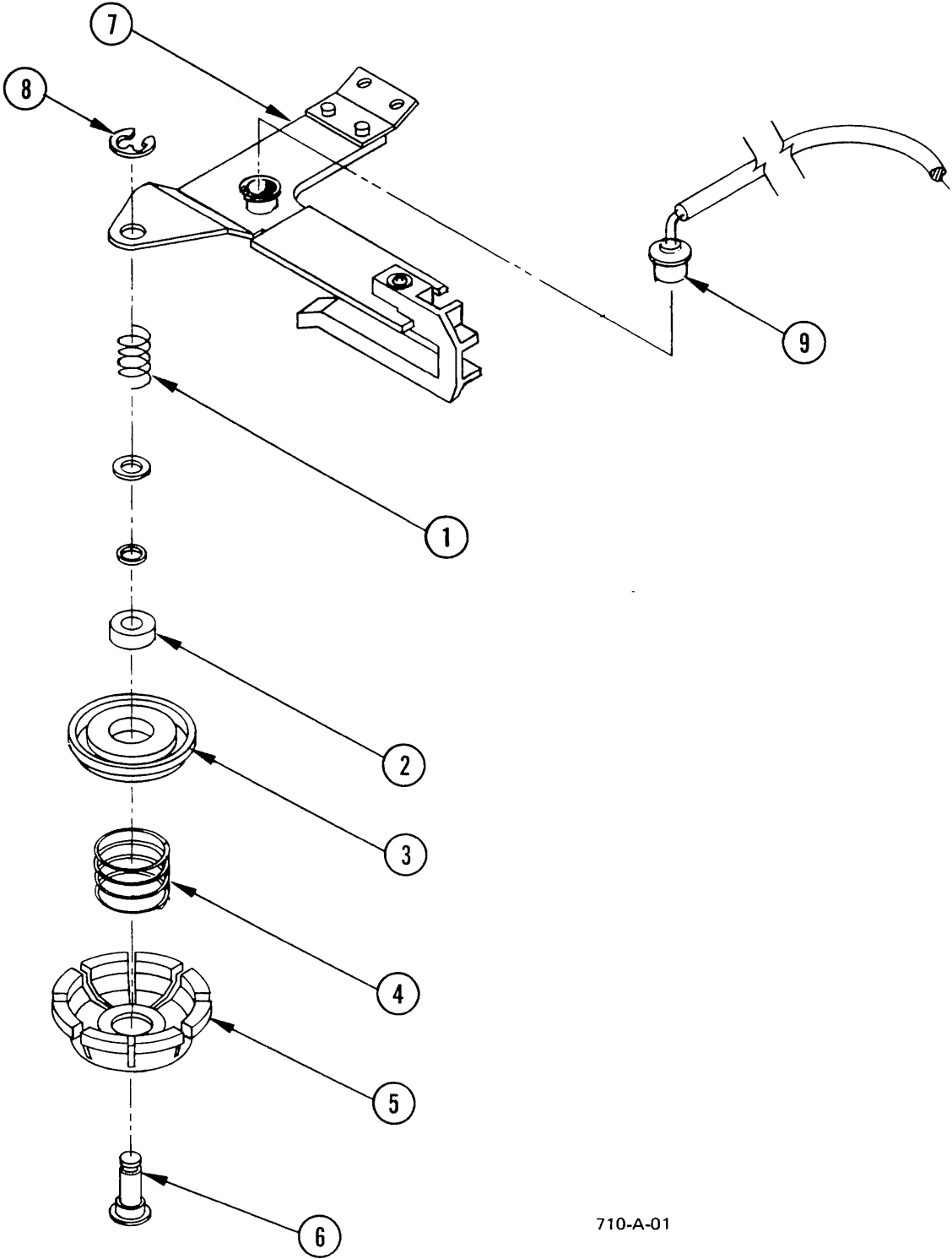

710-A-01

CARRIER ASSEMBLY

MEDIA GUIDE FRAME ASSEMBLY

<u>Item</u>	<u>Part No.</u>	<u>Description</u>
1.	-----	Frame Assembly (Note 1)
2.	53379-01	Media Guide Assembly Left
3.	53321-01	Media Guide, Right
4.	55163-14	Screw, M3 X 0.5

Notes:

- (1) Not available separately. Order complete drive assembly, .PN. 53301-XX.

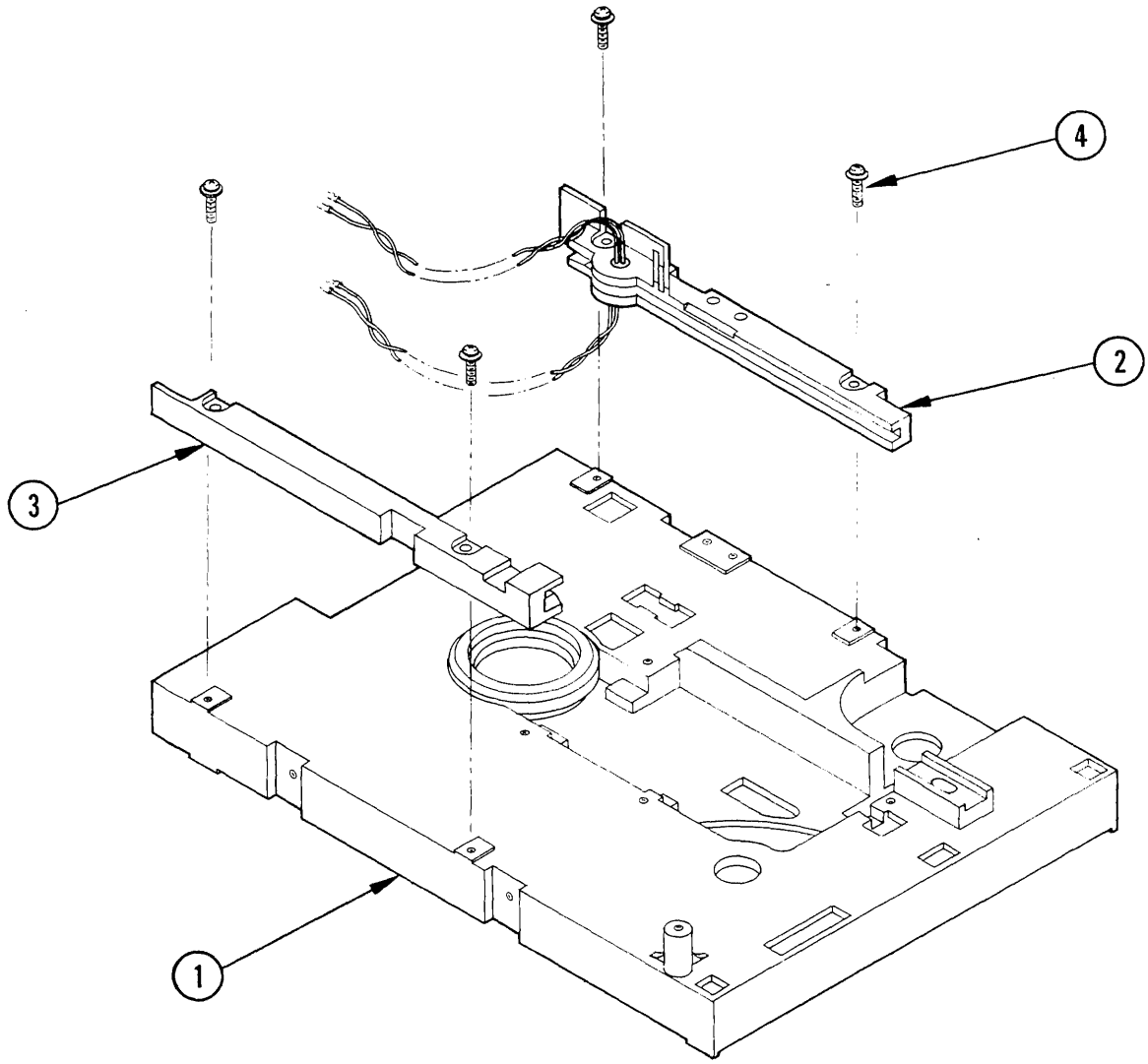

709-A-01

MEDIA GUIDE FRAME ASSEMBLY

DIAGRAMS

This section presents the following reference schematic diagrams for a typical QumeTrak 142 Flexible Disk Drive:

	DRAWING NUMBER	SHEET NUMBER
• PCB Component Location Diagram	90688-01	2
• Schematic Diagram	90688-01	4, 5

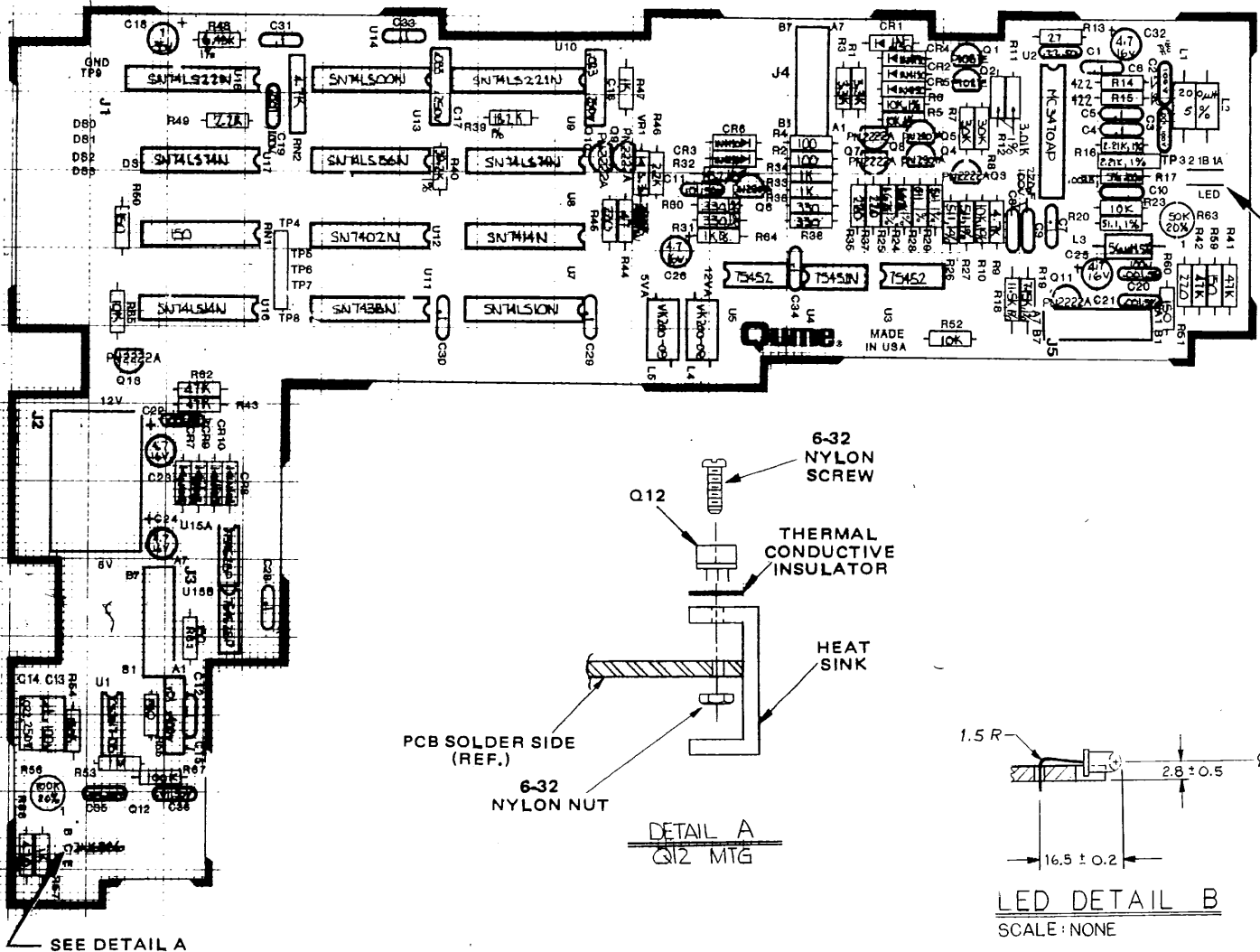

SEE DETAIL B

LED DETAIL B
SCALE: NONE

- NOTES - UNLESS OTHERWISE SPECIFIED:
1. ALL CAPACITANCE VALUES ARE IN MICROFARADS.
 2. ALL RESISTANCE VALUES ARE IN OHM, 1/4W, 5%.
 3. ALL 1% RESISTORS ARE 1/8W.
 4. ALL .1UF CAPACITORS ARE 50V, 20%.

DIMENSIONS SHOWN IN MILLIMETERS UNLESS OTHERWISE SPECIFIED TOLERANCES ARE:		DIMENSION G HING		DATE 6-16-82	
PREPARED BY J. K. H.		CHECKED BY J. K. H.		PCB-QUINE TRAK 142	
PROJECT/ITEM NO. 90685-01		SCALE 2/1		SHEET 2/31	

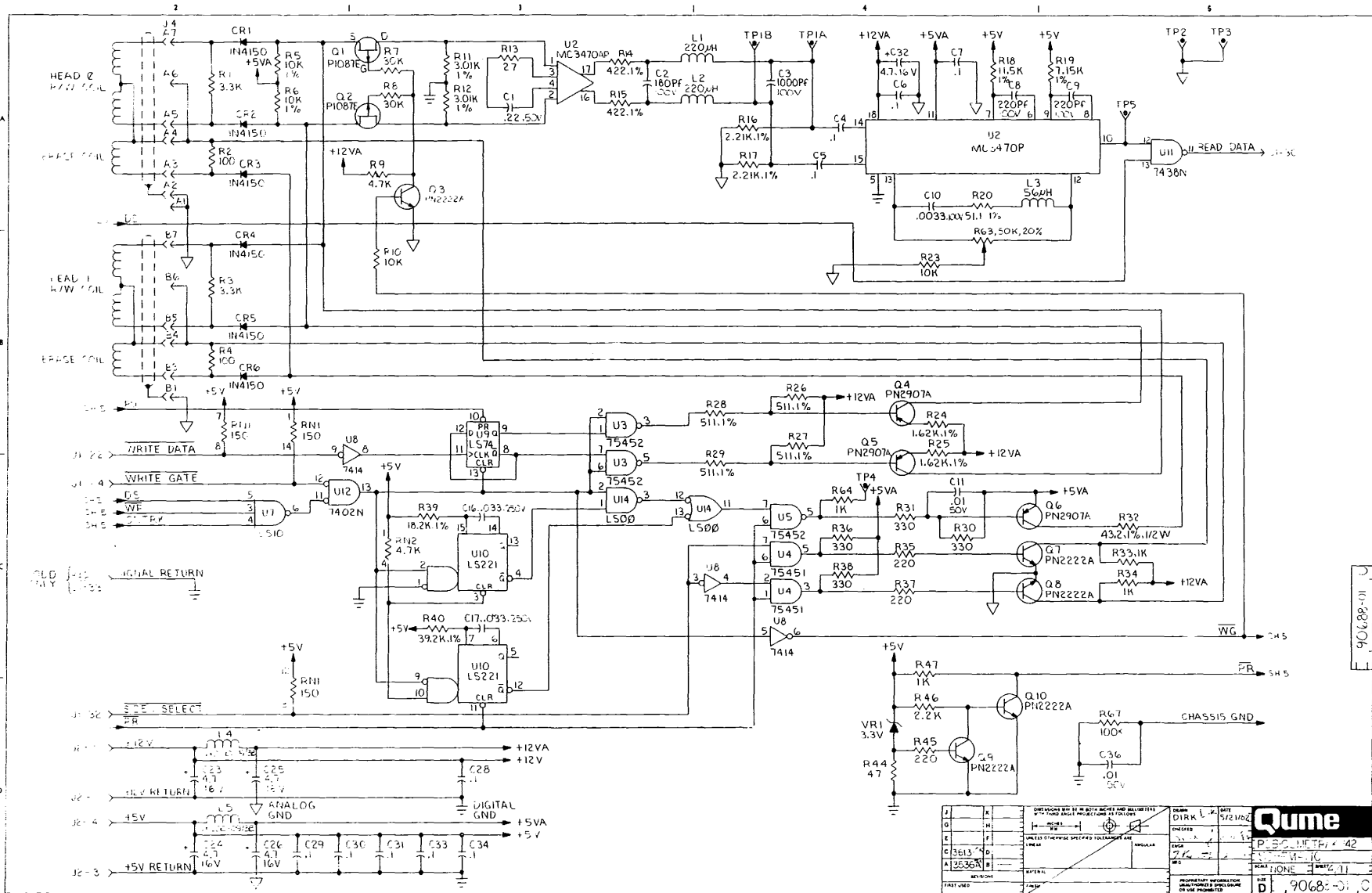

DESIGNED BY: [Signature]		DATE: 5/21/62	
CHECKED BY: [Signature]		DRAWN BY: [Signature]	
APPROVED BY: [Signature]		PARTS LIST: [Signature]	
TITLE: P-30 UNIT # 42		PHONE: [Signature]	
DATE: 9068-01		C	

DIAGRAMS

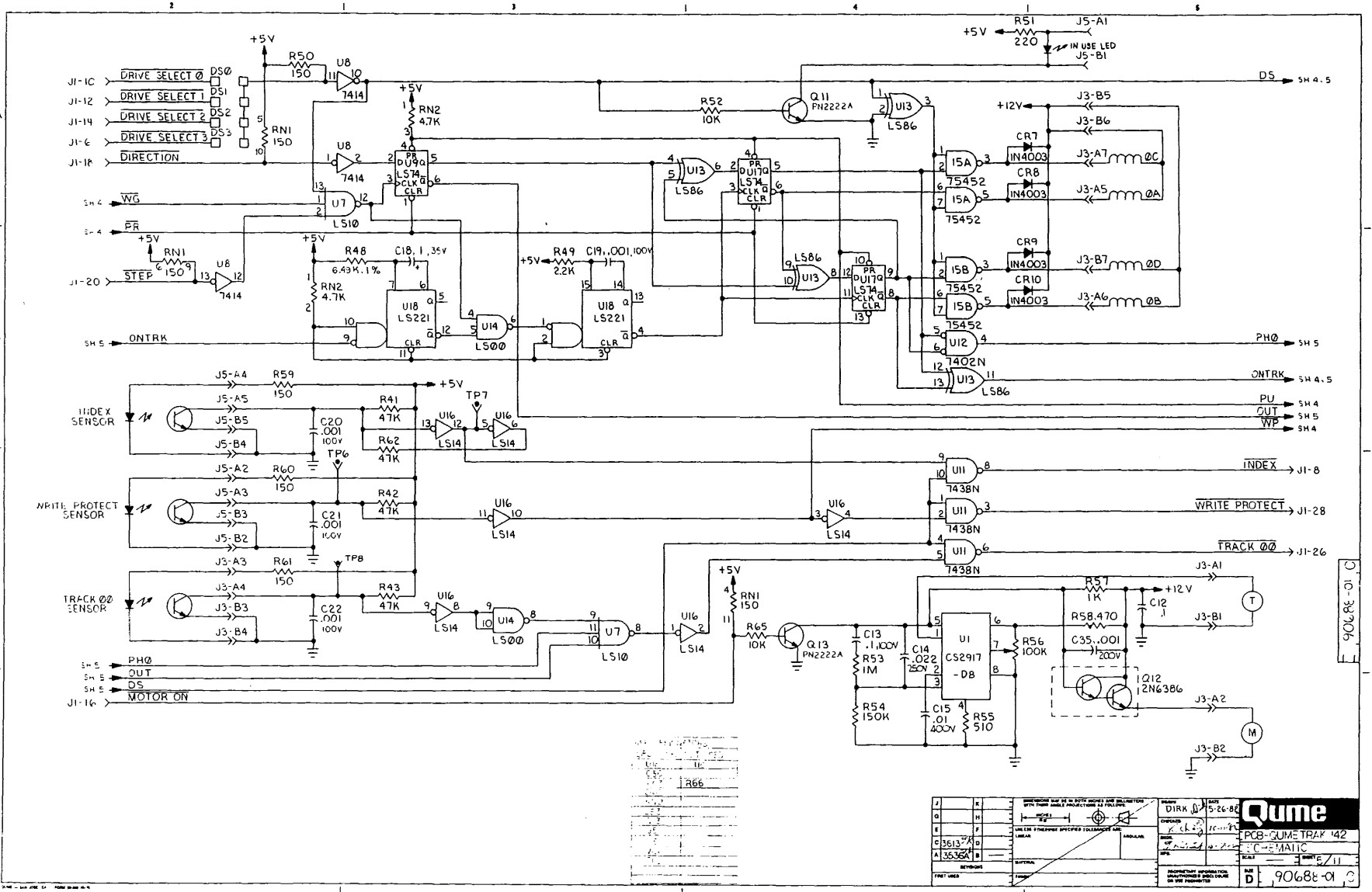

1	2	3	4	5	6	7	8	9	10	11	12	13	14	15	16	17	18	19	20	21	22	23	24	25	26	27	28	29	30	31	32	33	34	35	36	37	38	39	40	41	42	43	44	45	46	47	48	49	50
---	---	---	---	---	---	---	---	---	----	----	----	----	----	----	----	----	----	----	----	----	----	----	----	----	----	----	----	----	----	----	----	----	----	----	----	----	----	----	----	----	----	----	----	----	----	----	----	----	----

1	2	3	4	5	6	7	8	9	10	11	12	13	14	15	16	17	18	19	20	21	22	23	24	25	26	27	28	29	30	31	32	33	34	35	36	37	38	39	40	41	42	43	44	45	46	47	48	49	50
---	---	---	---	---	---	---	---	---	----	----	----	----	----	----	----	----	----	----	----	----	----	----	----	----	----	----	----	----	----	----	----	----	----	----	----	----	----	----	----	----	----	----	----	----	----	----	----	----	----

Qume
 PCB-QUMETRAK 142
 DATE: 5-26-84
 DESIGNED BY: [Signature]
 CHECKED BY: [Signature]
 DRAWN BY: [Signature]
 SCALE: 1/16" = 1"
 PART NO: 90688-01

INDEX

	PAGE
Adapter brackets.....	10
Addressing.....	12, 22
Aligning steel belt hole.....	61
Alignments.....	26
Azimuth check.....	41, 42
Basic troubleshooting subroutine flowchart.....	69
Belt end plates.....	59
Belt slippage.....	26, 28
Bronze spring.....	52
C-clamp plate.....	59, 61
Cable clamp.....	53, 64
Cable requirements.....	18, 20
Cable retaining slot.....	53
Cables.....	18
Carriage assembly.....	25, 43, 64, 77, 80
Carriage assembly adjustment.....	40
Carriage assembly base.....	59, 60
Carriage guide bar.....	64, 65
Carriage lifter arm.....	47, 51, 53, 62
Carrier assembly.....	47, 51, 53, 80, 82, 83
Carrier assembly removal.....	51
Carrier collet.....	52, 55, 77, 82
Carrier subassembly.....	82
Cats-eye pattern.....	37, 38
CE alignment diskette.....	25, 30, 37, 40
Certified R/W diskette.....	25
Cleaning diskette.....	25
Collet.....	52, 55, 77, 82
Collet access hole.....	24
Collet cone.....	77, 82
Collet spring.....	77, 82
Compatibility.....	3
Component location diagram.....	88
Cone spring.....	77, 82
Connector identification.....	18, 19, 20
Connector locations.....	21
Connector requirements.....	20
Connectors.....	18
Daisy chain.....	12, 18, 20, 22
Description.....	1
Dimensions.....	9
Direction select.....	15
Diskette capacity.....	1, 24

INDEX

	PAGE
Diskette care.....	24
Diskette identification.....	24
Diskette sleeve.....	24
Drive belt.....	26, 27, 44, 77, 80
Drive belt tension adjustment.....	26
Drive belt tension gauge.....	25, 26
Drive select.....	12, 16, 22
E-ring.....	77, 82
Eccentric.....	49
Feeler gauge.....	25, 31
Final assembly.....	80, 81
FM format.....	4
Frame ground.....	18, 20, 21, 26, 68
Front bezel assembly.....	23, 47, 80
Front bezel removal.....	47
Front bezel sizes.....	1
Glitches.....	68
Guide bar clamp.....	64, 65
Handle.....	23, 47, 49
Handle assembly.....	49
Handle assembly removal.....	47
Handle shaft.....	48, 49, 50
Handle shaft support.....	48, 49, 50, 80
Hard error.....	67
Head access slot.....	24
Head assembly spring clamp.....	62
Head azimuth.....	40
Head carriage.....	25, 43, 64, 77, 80
I/O signal interface.....	11
I/O signals.....	18
Illustrated parts lists.....	79
In use LED.....	23, 46, 48
Index.....	16
Index burst.....	33
Index burst timing.....	33
Index sensor.....	32, 56, 80
Index sensor alignment.....	32
Index sensor lamp.....	32, 56, 82
Index sensor removal.....	56
Index timing.....	16
Input level.....	11
Input lines.....	11

	PAGE
Installation requirements.....	8
Interface circuit.....	11
Interface connections.....	11, 13, 18
Introduction.....	1
Jumper locations.....	21
Jumpers.....	12, 22
Left media guide.....	53, 84
Left media guide position.....	34
Left media guide removal.....	54
Maintenance tools.....	25
Media.....	3
Media guide frame assembly.....	84, 85
Media guides.....	28, 29, 34
Media guides alignment.....	34, 35
Media guides alignment gauge.....	25, 34
MFM format.....	5
Motor on.....	12
Mounting positions.....	8
Operation.....	23
Options.....	1
Output level.....	16
Output lines.....	16
Packaging materials.....	7
PCB component location diagram.....	87
Physical interface.....	18
Power requirements.....	8
Printed circuit board.....	46, 77, 80
Protecting R/W head surfaces.....	43, 47
Publications.....	i
R/W diskette.....	23
R/W head alignment.....	40
R/W head azimuth.....	40
R/W head azimuth alignment.....	41
R/W head cables.....	64
R/W head cables position.....	34
R/W head cables routing.....	53
R/W head carriage assembly.....	25, 43, 64, 77, 80
R/W head carriage assembly adjustment.....	40
R/W head carriage assembly travel.....	62
R/W head carriage lifter arm.....	47, 51, 53, 62

	PAGE
R/W head carriage movement test.....	62
R/W head carriage removal.....	65
R/W head protection.....	43, 47
R/W head radial alignment.....	37, 38
R/W heads cleaning.....	37
R/W heads radial positioning.....	37
R/W test diskette.....	25
Read data.....	17
Read data timing (FM).....	17
Read data timing (MFM).....	17
Read error.....	67
Read error troubleshooting flowchart.....	73
Recommended spare parts.....	77
Releasing connector contacts.....	45
Reliability.....	2
Right media guide.....	53, 84
Right media guide position.....	34
Rotational speed.....	27
Rotational speed adjustment.....	28
Schematic diagram.....	87, 89, 91
Seek error.....	67
Seek error Troubleshooting flowchart.....	71
Service checks.....	26
Service policy.....	3
Shaft support.....	48, 49, 50, 80
Shipping damage.....	7
Side 0.....	16, 22
Side 1.....	16, 22
Side select.....	16, 22
Soft error.....	67
Soft sector.....	1, 24
Specifications.....	2
Spindle drive belt.....	26, 27, 44, 77, 80
Spindle drive belt tension.....	26
Spindle drive motor.....	27, 44, 77, 80
Spindle drive motor pulley.....	27
Spindle drive motor removal.....	44
Spindle hub.....	52
Spindle pulley.....	27, 44
Spring hook.....	25, 60
Stacking drives.....	10
Standard features.....	1
Steel belt.....	60, 80
Steel belt assembly.....	59, 77
Steel belt removal.....	59
Steel belt replacement.....	60
Step.....	15
Step timing.....	15
Stepper motor.....	39, 63, 77, 80
Stepper motor adjustment.....	39

	PAGE
Stepper motor pulley.....	59, 60, 61
Stepper motor removal.....	63
Storage.....	7
Storage capacity.....	1
Supply voltages.....	28
Tachometer.....	44
Tensioning spring.....	59, 61
Terminator.....	20
Terminator resistor, input line.....	20
Test diskette.....	25
Test point locations.....	21
Tie-down wire.....	47, 53
Timing requirements.....	14
Torque screwdriver.....	25, 33, 57
Track 00.....	17
Track 00 position.....	30, 43
Track 00 sensor.....	30, 58, 80
Track 00 sensor adjustment.....	30, 31
Track 00 sensor removal.....	58
Track 00 stopper bracket.....	31, 80
Track 39 position.....	34
Track access time.....	1
Track density.....	1
Training.....	3
Troubleshooting.....	67
Troubleshooting checks.....	67
Troubleshooting flowcharts.....	68
Unpacking.....	7
Visual inspection.....	68
Warranty.....	3
Write current.....	15
Write data.....	15
Write data timing (FM).....	15
Write data timing (MFM).....	16
Write enable notch.....	24
Write error.....	67
Write error troubleshooting flowchart.....	75
Write gate.....	16
Write protect.....	17
Write protect lamp.....	53, 54, 57
Write protect sensor.....	24, 29, 54, 57
Write protection.....	24



REQUEST FOR READER'S COMMENTS

Qume Corporation attempts to provide documents that meet the needs of all Qume product users. This form lets you participate directly in the documentation process.

Please restrict your comments to the usability, accuracy, readability, organization, and completeness of this document.

1. Please specify by page any errors you found in this manual.

2. Does the document cover the information you expected or required? Please make suggestions for improvement.

3. Is this the right type of document for your needs? Is it at the right level? What other types of documents are needed?

4. Did you have any difficulty understanding descriptions or wording? Where?

5. Please rate this document on a scale of 1 to 10 with 10 being the best rating _____

6. Dealer/Distributor where product purchased: _____

NAME _____ DATE _____

TITLE _____

COMPANY NAME/DEPARTMENT _____

ADDRESS _____

ITY _____ STATE _____ ZIP CODE _____

Please check here if you require a written reply.

WE'D LIKE YOUR COMMENTS . . .

This document is one of a series describing Qume products. Your comments on the back of this form will help us produce better manuals. Each reply will be carefully reviewed by the responsible person. All comments and suggestions become the property of Qume Corporation.

PLACE
POSTAGE
HERE

Qume Corporation
Attn: Technical Publications
2350 Qume Drive
San Jose, CA 95131